

Partial C.I.P Top Concrete Coping Elevation

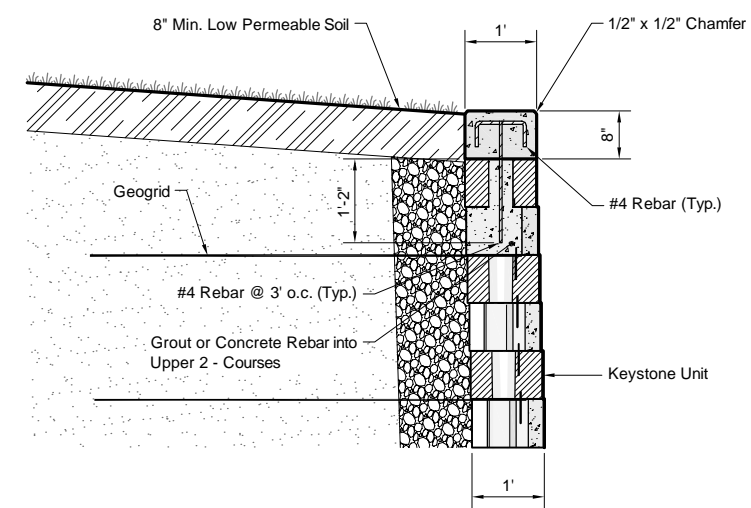

Section D - D  
C.I.P. Top Concrete Coping

- Note:**
- Maintain 2" minimum cover on all rebar.
  - Full expansion joints shall be placed every 3rd joint and at all wall radius and bend points.

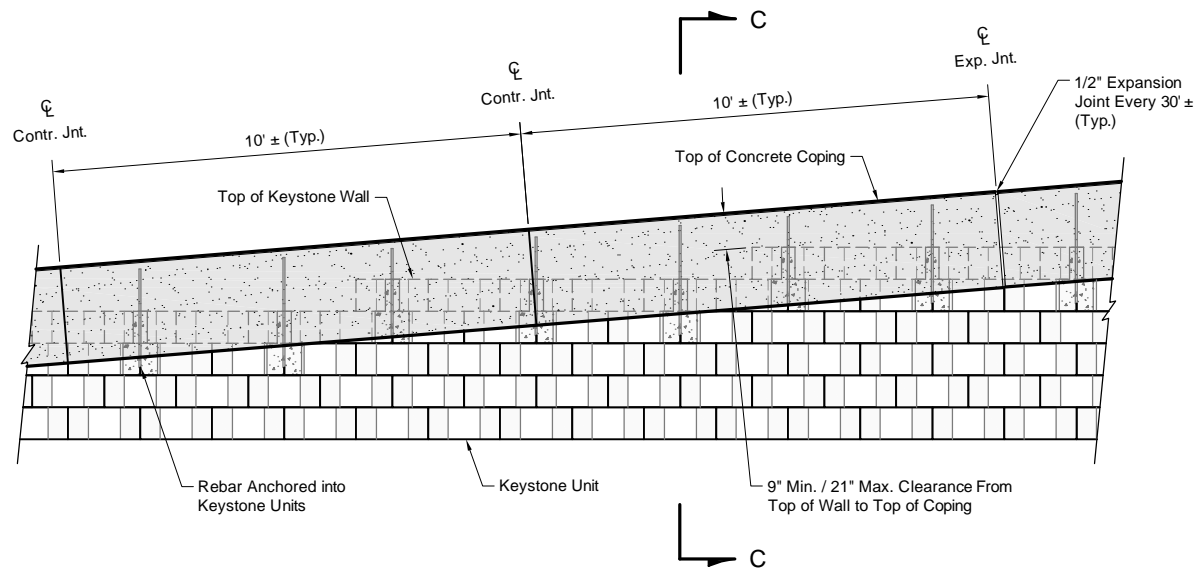

Partial C.I.P Concrete Coping Elevation

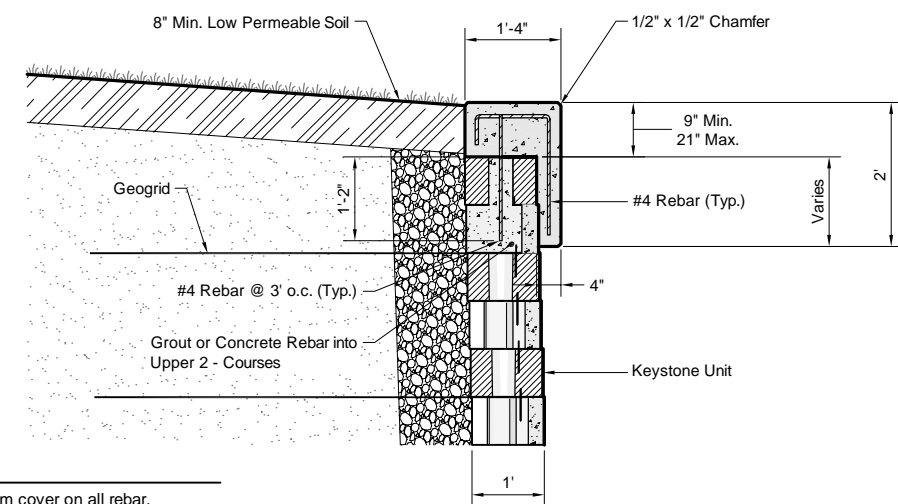

Section C - C  
C.I.P. Concrete Coping

- Note:**
- Maintain 2" minimum cover on all rebar.
  - Full expansion joints shall be placed every 3rd joint and at all wall radius and bend points.
  - Insure that all top of wall steps are completely covered by overhang of concrete coping (3" min.).

Copyright 2003 Keystone Retaining Wall Systems

Design is for internal stability of the KEYSTONE wall structure only. External stability, including but not limited to foundation and slope stability is the responsibility of the Owner. The design is based on the assumption that the materials within the retained mass, methods of construction, and quality of materials conform to KEYSTONE's specification for this project.

This drawing is being furnished for this specific project only. Any party accepting this document does so in confidence and agrees that it shall not be duplicated in whole or in part, nor disclosed to others without the consent of Keystone Retaining Wall Systems, Inc.

No.	Date	Revision	By



Designed By: RKM	Title: Cast in Place Coping Details	Date:
Checked By: CDM	Project: Keystone Retaining Wall Systems Typical Wall Details	Project No:
Scale: No Scale		Drawing No: