

With proper design methods, Keystone® Retaining Walls can be built to retain a variety of site conditions. Before construction begins, review standard design guidelines and engineering requirements. Will the retaining wall be a “non-critical” structure falling within basic design and construction methods or will it be a “critical” structure requiring strict engineering documentation? The following list describes site conditions which will require a full engineering study. Consult local building officials for specific requirements. For questions relating to the functionality of the Keystone® units in any of these conditions, contact a Keystone® representative.

- ▶ The wall height, including terraces, exceeds 6’ (1.8m) for Standard Units, or 3’ (0.9m) for Mini or Compac Units.
- ▶ The wall will be built on unstable soils, such as clays or organic materials.
- ▶ The wall will encounter hydrostatic loading or erosion from wave action, drainage or site runoff.
- ▶ The wall will encounter loading conditions resulting from slopes or structures behind or above the wall.
- ▶ The wall will use geogrid soil reinforcement or other mechanical anchoring devices.

The following construction procedures assume that all design or engineering issues have been addressed. These installation instructions apply to the Keystone® Standard, Compac, and Mini Units. Proceed with construction using tools common to the construction industry. At a minimum, you will need a level or transit and tools or equipment to dig a trench and place and compact the backfill.

▶ **STEP 1: PREPARE SITE**

Remove all surface vegetation and debris. This material should not be used as backfill. If required, excavate site soils to allow for placement of the Keystone® units. If a wall is being built on fill, this step may not be necessary.

▶ **STEP 2: EXCAVATE BASE TRENCH**

After selecting the location and length of the wall, excavate the Base Trench. This lowers the first course below grade creating a passive wedge of soil to resist sliding. In addition, it helps prevent erosion and scouring at the base of the wall. The Base Trench should be wide enough to allow for the Keystone® Unit and Drainage Zone. The Drainage Zone, an area of crushed stone material, promotes the release of hydrostatic pressures (see STEP 6 for specific depth requirements).

**QUESTION:** How wide does the Base Trench need to be?

**ANSWER:** A minimum 24” (610mm) wide for all units.  
**NOTE:** additional excavation width may be required if geogrid or other mechanical reinforcement will be used.

The Base Trench must be dug deep enough to allow for placement of the Base Leveling Pad and any buried Keystone® units.

**QUESTION:** What should be the depth of the Base Leveling Pad?

**ANSWER:** A depth of 6” (150mm) is standard.  
**NOTE:** Keystone® walls less than 3’-0” (1m) high, built on firm, inorganic original soils require no Base Leveling Pad. Level and compact soils in the Base Trench. Requirement for additional depth of leveling pad material must be determined by an engineer.

**QUESTION:** How many Keystone® units should be placed below grade?

**ANSWER:** Wall Height (in feet) x 1.5 = depth of units (in inches) below grade.  
Wall Height (in meters) x .125 = depth of units (in meters) below grade. (1” (25mm) of wall buried below grade for each 8” (203mm) of wall above grade).

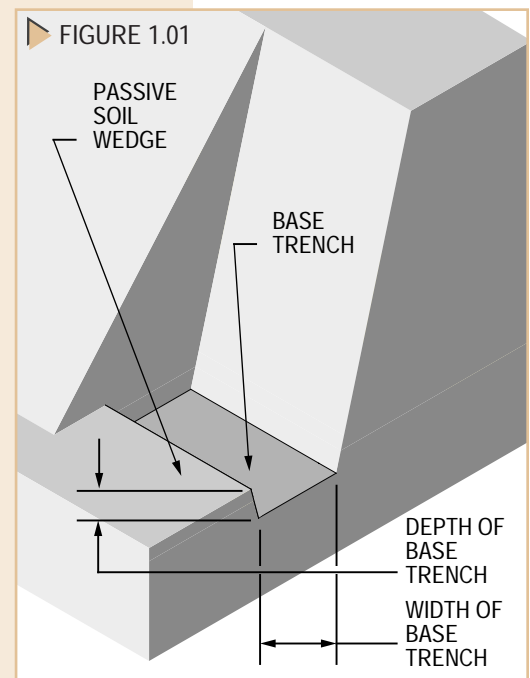

EXAMPLE:  $8'H \times 1.5 = 12"$  ( $2.4mH \times 0.125 = 0.305m$ ) of wall unit below grade.

NOTE: The number of buried courses should not exceed three unless otherwise specified by engineering.

The combined depths of the Base Leveling Pad and buried units is the total depth of the Base Trench.

QUESTION: What should be the depth of the Base Trench?

ANSWER: Depth of wall units below grade + Base Leveling Pad = depth of the Base Trench (following above example)  
 $12" + 6" = 18"$  ( $0.3m + 0.15m = 0.45m$ ) depth of Base Trench below grade

There are three exceptions to this rule for determining the proper depth of the Base Trench.

1. Poor soil conditions may require a much larger depth of Base Leveling Pad material or soil reinforcement. This extra material would be used to improve the bearing capacity of the sub grade to fully support the weight of the retaining wall. A Geotechnical engineer should evaluate such concerns.

2. Construction of a wall on a slope (figure 1.02). When using the standard Base Trench guidelines, the amount of passive soil in front of a wall constructed on a slope is reduced significantly. This requires an increase in the Base Trench to meet minimum requirements.

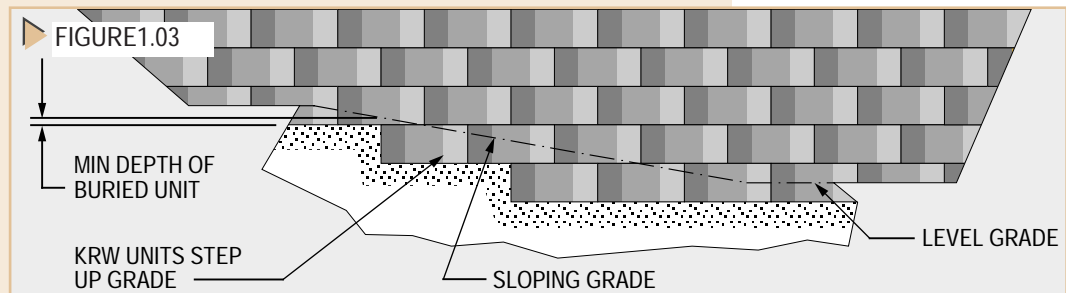
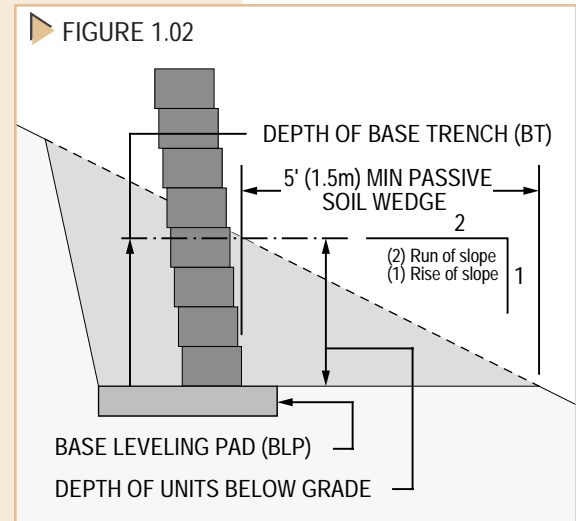

QUESTION: What should be the depth of the Base Trench for walls constructed on slopes?

ANSWER: Minimum distance from front of first course to daylight on the slope  $\div$  run of the slope = depth of units below grade + depth of Base Leveling Pad = depth of Base Trench below grade..

EXAMPLE:  $5' (1.5m) \div 2$  (run of slope) =  $2.5'$  ( $0.75m$ ) (depth of units below grade) +  $6"$  ( $0.15m$ ) =  $3'$  ( $0.9m$ ) depth of Base Trench below grade

3. Stepping units up along a sloping grade (figure 1.03). When the grade running parallel with the wall is not level with the top or bottom of the Keystone® units, the depth of the Base Trench and depth of the units below grade will vary. Maintain the minimum depth of buried Keystone® Units.

▶ **STEP 3: PLACE AND COMPACT BASE LEVELING PAD**

Begin first by selecting the proper Base Leveling Pad material.

QUESTION: What material should be used for the Base Leveling Pad?

**ANSWER:** Granular inorganic soil (i.e. Class #5, Burma, Road Base). Its maximum particle size is 3/4" (20mm). Its minimum particle size is no more than 10% of the volume passing a No. 200 sieve. Using larger material will make leveling more difficult. The following are specific options:

- OPTIONS:**
1. 3/8" to 3/4" (10 - 20 mm) crushed stone in areas with high moisture levels.
  2. Angular sand, stone sand, etc. in areas with low moisture levels.
  3. A 2000± psi.(140±kg/em<sup>2</sup>) non-reinforced concrete leveling pad, 1" (25mm) to maximum 3" (75mm) thick.
  4. A 3500 psi.(246±kg/em<sup>2</sup>) reinforced concrete footing. This option is used only in critical applications as recommended by an engineer.

**NOTE:** Do not use pea rock or rounded aggregate for the base leveling pad.

The rounded surface of these materials yields low friction in compaction and allows a greater potential for wall movement.

Place selected Base Leveling Pad material and compact with appropriate equipment to achieve proper density. Compact granular materials to 95% Standard Proctor or 90% Modified Proctor (soil testing standards to determine % of maximum soil density). Crushed stone should be compacted to yield (Proctor testing can not be performed on crushed stone material.). Requirements for the type of testing program, locations and frequency is the responsibility of the engineer of record or owner. Compact the Base Leveling Pad to a level condition. Check for accuracy using a level/transit or hand level. Use some sand or fine granular material for minor adjustments. If a concrete (non-reinforced) leveling pad is being used, set batter boards, pour concrete, and screed level.

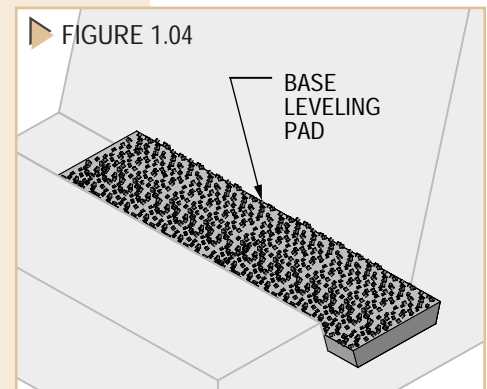

When building on a level grade condition, the Base Leveling Pad is placed for the full length of the wall before Keystone® units are installed. Walls built on a sloping lateral grade may require a stepped base (figure 1.03). In these conditions, the Base Leveling Pad and the first course of Keystone® Units are installed for each length of a step in grade (figure 1.07). Beginning at the lowest elevation, place and compact the Base Leveling Pad material. Next, install the first course of Keystone® units. After leveling and alignment of these units is complete, place and compact the Base Leveling Pad for the next step in grade. While doing so, place the same material around the units closest to the step in grade to stabilize their position. The top of the last Keystone® unit becomes the grade level for the top of this Base Leveling Pad. This unit retains the Base Leveling Pad material for this next step in grade. If site conditions necessitate, building in the opposite direction, from a high to low elevation, is possible though significantly less efficient. This method will require greater skill to level and align the Base Leveling Pad with the last Keystone® unit of the preceding course.

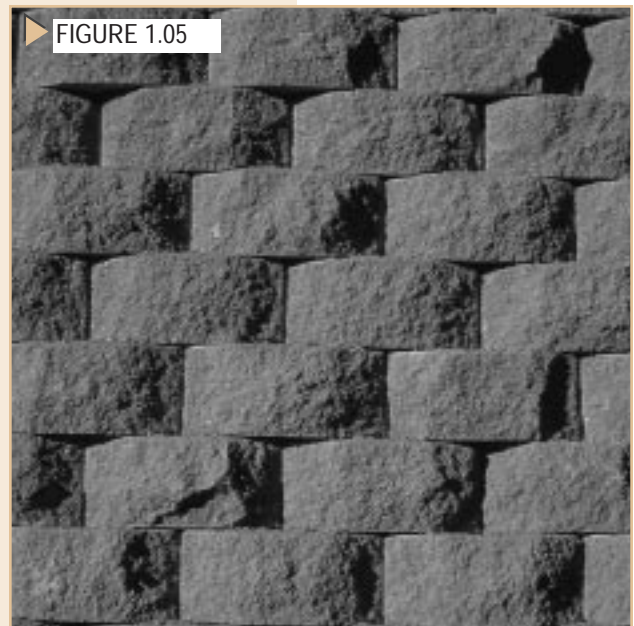

► **STEP 4: SET AND ALIGN THE BASE COURSE**

Begin at lowest wall elevation. Place all units parallel to the alignment line. The machined edges (figure 1.05) of adjoining units should contact each other. This procedure applies to straight walls (see section on "CURVES" for related information). If slag material protrudes past the corner, chip back to allow corners to contact properly. Be sure all units are set top side up. The top side has four pin holes centered between the two kidney receiving holes (figure 1.06). All units should rest firmly on the Base Leveling Pad. If any rocking motion occurs, adjust base leveling pad material or units to achieve solid contact with this surface.

Check and adjust the level and alignment of all units. The position of the Base Course determines the alignment of all succeed-

ing courses. Adjustments to alignment must be made at this time. Do not align the units using the split face surface. Instead, verify the proper position of all Keystone® units by examining a straight line across the back of the units or over the top of unit holes (figure 1.06).

Level Keystone® units side to side using a 48" (122cm) or longer level. Units can be leveled front to back using a minimum 24" (61cm) level. If a level/transit is used, spot check every 4th or 5th unit. The top surface of two adjoining units should align (+) or (-) 1/8" (3mm). Minor height adjustments can be made by tapping the unit with a rubber mallet or by placing small amounts of coarse sand under the units. Applying excessive vertical force in an attempt to adjust the height alignment could produce stress fractures. Placement of more than 3/4" (20mm) of loose material could lead to unacceptable settlement.

All Base Course units can be placed for an entire wall length or for a small segment of the full length. To reduce the movement of base units from construction equipment, place core material after placement and leveling of each ten units. When placing the Base Course for a wall with a stepping grade, set all units at the lowest grade elevation first. Secure the position of these units as described in STEP 2. Placement of the Base Course for the next step in grade should begin by placing a minimum of 1-1/2 overlapping units (figure 1.07). This will ensure proper interlock position for additional units.

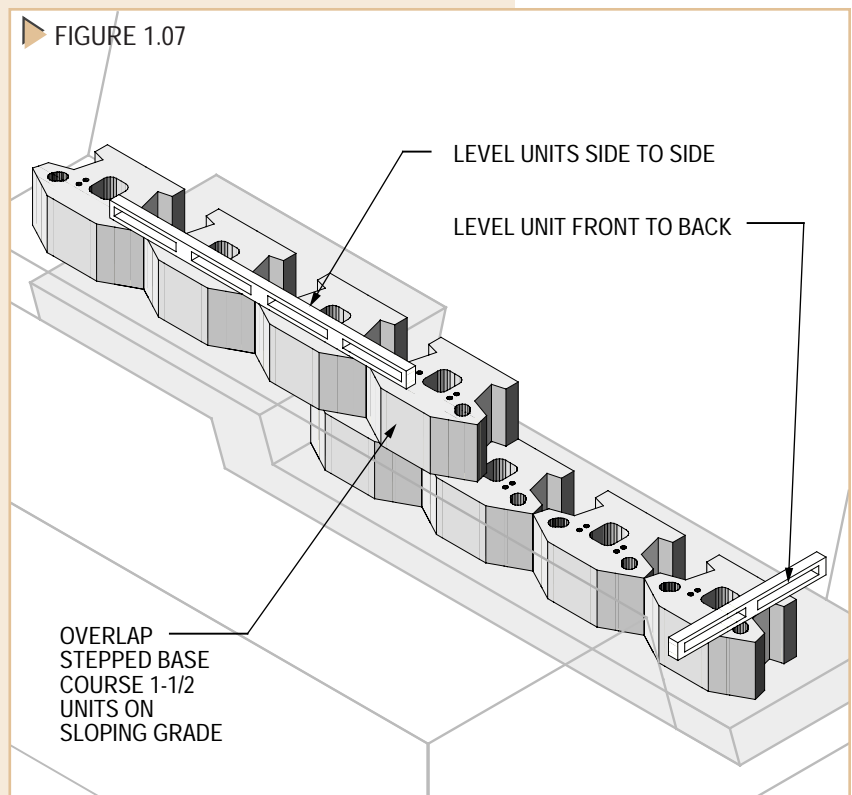
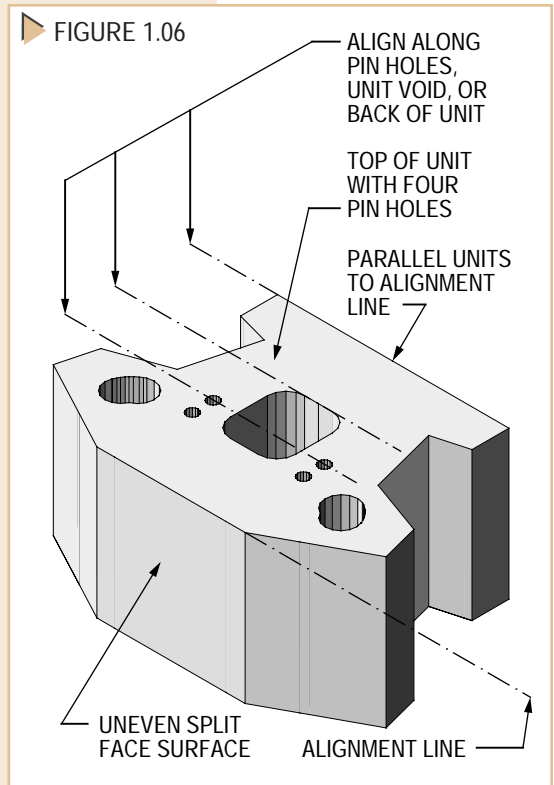



INSTALLATION

▶ INSTALLATION - STEP BY STEP

▶ STEP 5: INSERT FIBERGLASS CONNECTING PINS (figure 1.08)

Before installing the pins, select a batter option. "Batter" is the slope of the face of a wall upward and backward so that the wall leans into the embankment being retained. With Keystone®, batter is mechanically controlled by the pin position. Units with four pin holes appearing in the top of the Keystone® unit have three batter options; 8.8° (1-1/4" [30mm]), 4.4° (5/8" [15mm]) or near vertical. Units with only two pin holes appearing in the top of the Keystone® unit result in a 4.4° batter (figure 5.2).

QUESTION: Which batter option should be used?

ANSWER: A 4.4° or 8.8° batter may be used for any installation. Non-geogrid reinforced walls should use this batter for greatest stability. Straight walls are well suited for this batter option. A near vertical batter works well for tall geogrid reinforced walls with tight radius curves and corners.

NOTE: See "CORNERS AND CURVES " section for the effect of batter on curved walls.

Place two Keystone® pins into two of the preformed holes in the top of each Keystone® unit. In some cases a light slag film may cover part or all of the hole. In these conditions, use a hammer to tap the pin through the concrete slag and into the opening . Once in position, a minimum

▶ FIGURE 1.08

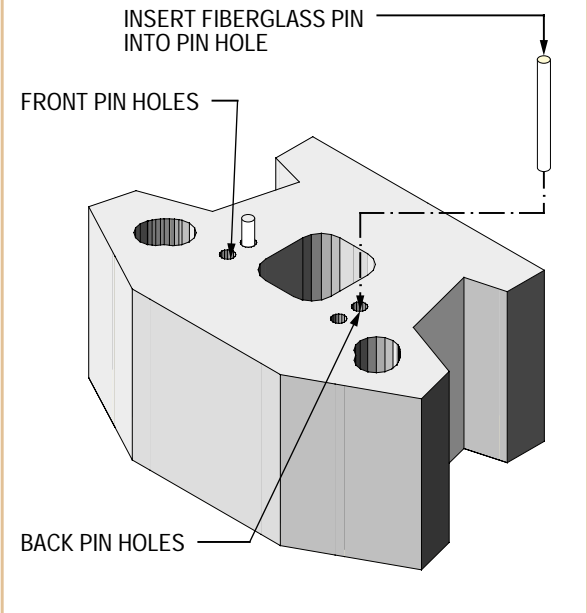

▶ FIGURE 1.09

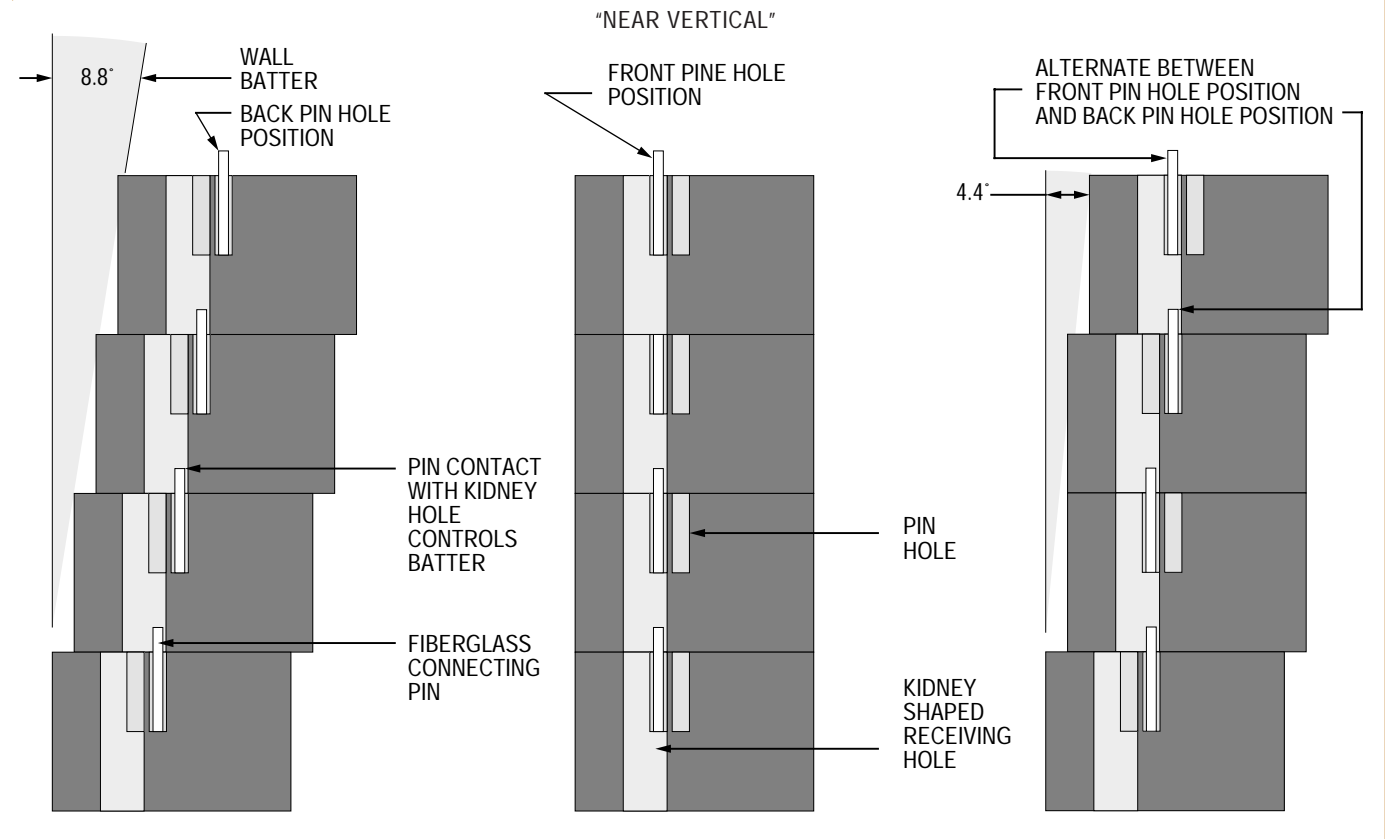

The information contained herein has been compiled by Keystone® Retaining Wall Systems, Inc. and to the best of our knowledge, accurately represents the Keystone product use in the applications which are illustrated. Final determination of the suitability for the use contemplated and its manner of use are the sole responsibility of the user. Structural design and analysis shall be performed by a qualified engineer.  
© 1997 KEYSTONE RETAINING WALL SYSTEMS, INC.  
Minneapolis, Minnesota • (612) 897-1040 • (612) 897-3858-fax

1-1/4" (30mm) segment of the pin should protrude out of the opening above the top surface of the unit.

▶ **STEP 6: PLACE UNIT/DRAINAGE MATERIAL**  
(figure 1.10)

Fill the Keystone® unit voids and Drainage Zone with an inorganic free draining granular material (preferably 3/4" (20mm) crushed stone). The unit voids are the openings and spaces between units. The Drainage Zone is the combined area of the unit voids and/or additional area behind the unit. The width of Unit/Drainage material should be approximately 24" (61cm), measured from the wall face to the back of the trench (for specific volumes required to fill a Compac or Standard Unit, refer to the Standard or Compac Unit Keynote). Certain site conditions may require a greater width of this material. Place material into the specified area. A crushed stone material will consolidate naturally. Graded granular or coarse sand material may require hand compaction. Do not operate any automated compaction equipment directly over the Keystone® units in an attempt to compact this material. This may result in stress fractures.

Proper placement of the Unit/Drainage material serves three important purposes. First, placing this material between units on adjoining courses creates a positive interlock between units. If geogrid reinforcement is used, friction interlock with the wall face is significantly improved. In addition, this material will increase the overall weight of each Keystone® unit; a very important feature for simple gravity retaining walls. Finally, it will permit the release of hydrostatic pressures which build up behind the wall face. The Unit/Drainage material used in this procedure should be the same as is described in Step 3 (Points 1 & 2). If fine grain material is used (i.e. sand), water percolation may move some of these particles out of joints between units and over the wall. The presence of soil on the unit faces may cause some discoloration and an unacceptable appearance. To eliminate this problem, place a piece of filter fabric between each unit. This will allow moisture to flow out of the face while trapping soil fines. A larger aggregate material such as crushed stone will filter most soil fines found in retained site soils. This back-filling procedure should occur after placement of each Keystone® course. When building with the Standard Unit, an alternate technique may be used. The size of this unit and its voids will allow them to be laid up to three courses high prior to placement of the Unit/Drainage material. To use this construction procedure, the material must be clean 3/4" (20mm) crushed stone. Natural consolidation of this material will occur during construction. If geogrid reinforcement is used, backfill units before placing geogrid layers. Attempting to backfill through the geogrid openings will not allow the placement of the Unit/Drainage material into the unit voids.

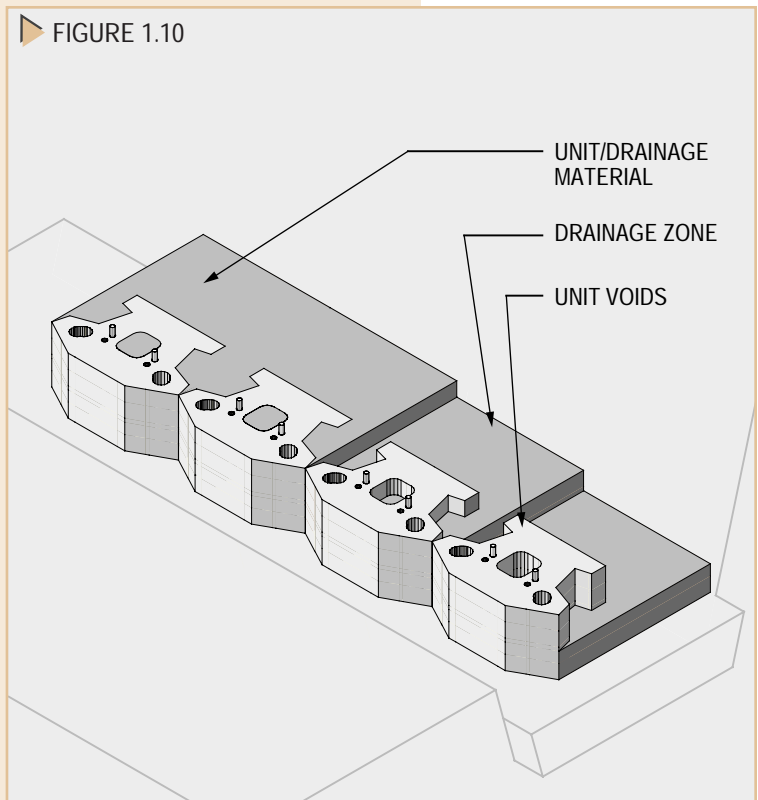

▶ **STEP 7: BACKFILL AND COMPACT SOILS.**

The depth of this area will vary depending on the site conditions and construction procedures used. Walls constructed in a fill condition will require the placement of large volumes of this material. Walls built into cut conditions will require varying quantities of material depending on the amount of over excavation.

The same placement rules apply for each condition. In general, all soils should be placed in no more than 8" (20cm) thick lifts, the height of a single Keystone® unit. More specifically, the proper thickness of material placed in a single lift is dependent on the type of soils and compaction equipment being used. For example, crushed stone (used for Unit/Drainage) may be placed in maximum lifts and will compact with minimal effort. Most inorganic site soils, easily influenced by moisture levels, must be placed in shorter lifts and will require greater compaction effort.

What about compaction? The backfill soils need to be compacted to a minimum 95% Standard Proctor (95% of the soil's maximum density). Both the type of material and the compaction equipment need to be considered when addressing this issue. Soils compacted with walk behind equipment will require the placement of thin layers of material. Using ride-on mechanical equipment will allow placement of thicker lifts of material. Consult an engineer for specific recommendations. The following are basic guidelines:

- Backfill material must have the proper moisture content for optimum performance when compacting.
- Organic or heavy clay material should not be used. These materials hold moisture and do not compact properly.
- Walk behind mechanical compaction equipment may be used to compact any soils placed beyond the Unit/Drainage zone.
- Ride-on mechanical compaction equipment should be operated no closer than within 3' (1m) of the Keystone® Unit back surface.
- Do not over compact or compact soils next to the back of the unit in an uncontrolled manner. This may drive drainage material under the unit, forcing the units out of level. If this continues, the wall may begin to lean forward.
- All soil testing should be performed by a qualified engineer. Soil tests should be taken no closer than three feet from the back surface of the Keystone® unit.

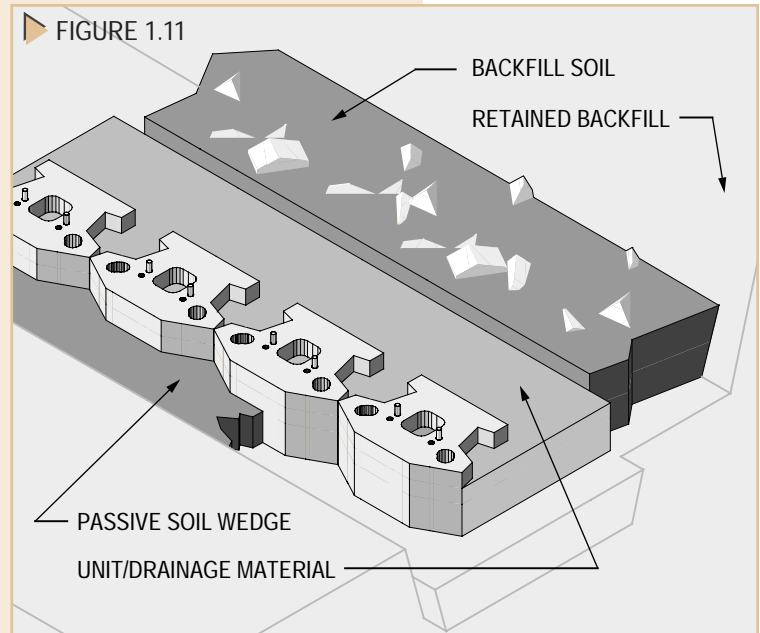

While placing backfill material behind the first course of Keystone® units, replace the passive soil wedge at the front of the units. This will secure the proper alignment of all units (see figure 1.11).

▶ STEP 8 : SWEEP TOP OF UNITS CLEAN

Remove all excess unit/drainage material from the top surface of all units. This allows a smooth surface for placement of the next course of Keystone® units. If small stones become sandwiched between units, point loading may occur resulting in stress fractures. This material may also leave units out of level, creating visual distortion. If due to the manufacturing process, ridges or slag material are present, remove by using a tool or use the next course unit being placed to rub the high spot off.

▶ STEP 9: INSTALL ADDITIONAL COURSES OF KEYSTONE UNITS (figures 1.12 - 1.15)

Place additional courses of Keystone® units. Each unit will be placed over two units below creating a running bond face pattern. Easiest placement of the Keystone® units is accomplished in the following steps:

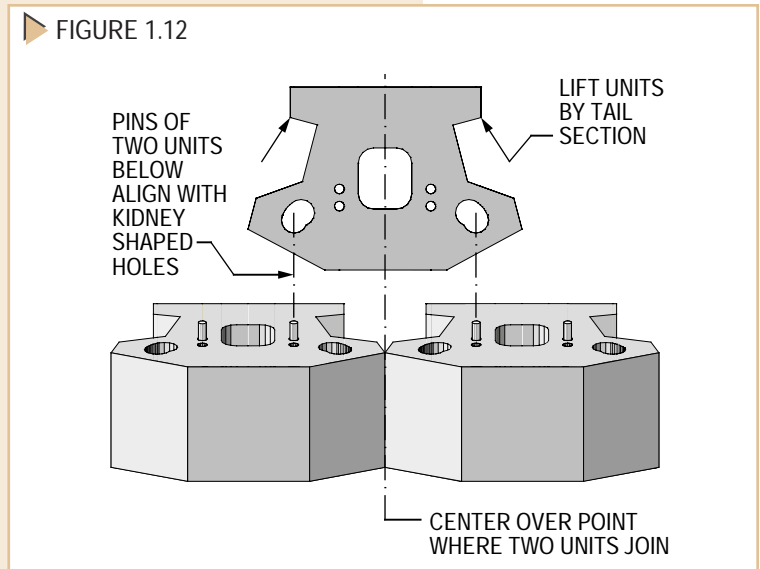

► FIGURE 1.13

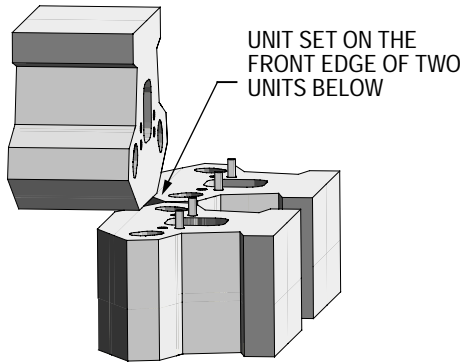

- Lift each Keystone® unit by its back tail section to move it into position.
- Center the unit in front of the point where the two units below meet.
- Set the face of the unit onto the front edge of the two units below.
- With the Keystone® unit in this position, slowly lower it to contact the two units below. While lowering the unit, the two kidney receiving holes should slip over one fiberglass pin in the units below (open kidney will allow a visual check).
- Pull the unit forward to engage pins. The unit will be locked into a batter position. Visually check to see that the unit is parallel to the units below. After setting a length of Keystone® units, visually check the overall alignment. Make minor adjustments as necessary.

► FIGURE 1.14

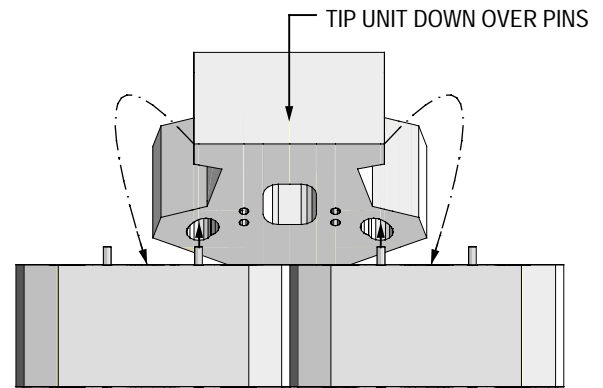

► FIGURE 1.15

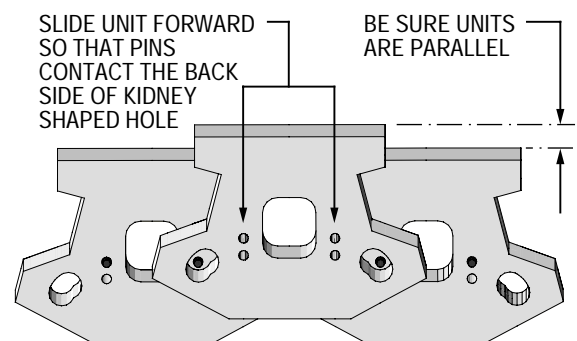

► STEP 10: CONTINUE WITH STEPS 5-9 UNTIL ALL KEYSTONE UNITS ARE INSTALLED

► STEP 11: POSITION AND SECURE CAP UNITS

Follow the same procedures described in STEP 9 for proper placement and positioning of the Keystone® cap units. A variety of sizes and shapes, including 4" (100mm) and 8" (200mm) high units, have been designed to satisfy most installation needs. Availability of these units will vary from region to region. For cap unit descriptions and placement variations, see the section on, "WALL CAP: USING KEYSTONE UNITS" in this manual.

Cap units may be secured with a bonding material to prevent their removal. Final alignment at the top of the wall may also require this same procedure. If due to final alignment repositioned cap units do not properly meet pin connections, then remove the pins and secure these cap units with the bonding material. Due to the flexibility or non-rigid qualities of the Keystone® system, the bonding material must be able to tolerate some movement. Keystone® KapSeal™ adhesive is designed for this use with a special formulation to withstand temperature and moisture extremes. If this material is unavailable, other flexible epoxy based adhesives designed to bond masonry to masonry may be used. Refer to manufacturers instructions for complete details.



▶ **STEP 12: FINISHED GRADE AND LANDSCAPING**  
(figure 1.16)

The Keystone® Retaining Wall is complete. Final grading, planting or other surface materials can now be put into place. Remember that finished grade conditions affect the wall's performance. Such conditions should not be altered from the original design. Loading with slopes, parking lots and buildings should be maintained as designed. Any changes to the top of wall finished grade must be evaluated prior to construction.

**SPECIALIZED CONSTRUCTION TECHNIQUES**

The following are a list of specific construction techniques that may be related to the construction of a Keystone® wall. See other sections in this manual for further details.

- Geogrid reinforcement
- Drainage issues
- Pipes and culverts through the wall face
- Guard rails
- Barriers
- Fences and poles
- Structures
- Curbs and copings
- Water Applications
- Terraces
- Light Fixtures and signage
- Mixing unit sizes.

