

C O R N E R S A N D C U R V E S

▶ 90° INSIDE CORNER - ROUNDED

No need to purchase special units for construction of these corners. The following information will provide a complete explanation of construction techniques for building retaining walls with these conditions.

INSTALLATION PROCEDURES:

- ▶ Follow standard installation instructions for preparation of sub grade and leveling pad.
- ▶ Place units tight to each other starting with the first course as shown.
- ▶ Follow standard installation instructions for back filling and placement of additional courses.
- ▶ If geogrid reinforcement is used, refer to manufacturers recommendations for proper placement of this material at corners.
- ▶ Depending on wall height, and batter selection some gapping between units may occur. If gaps exceed acceptable limits, re-drill new pin holes as needed using a 5/8" (15mm) masonry bit and realign units to close gaps.

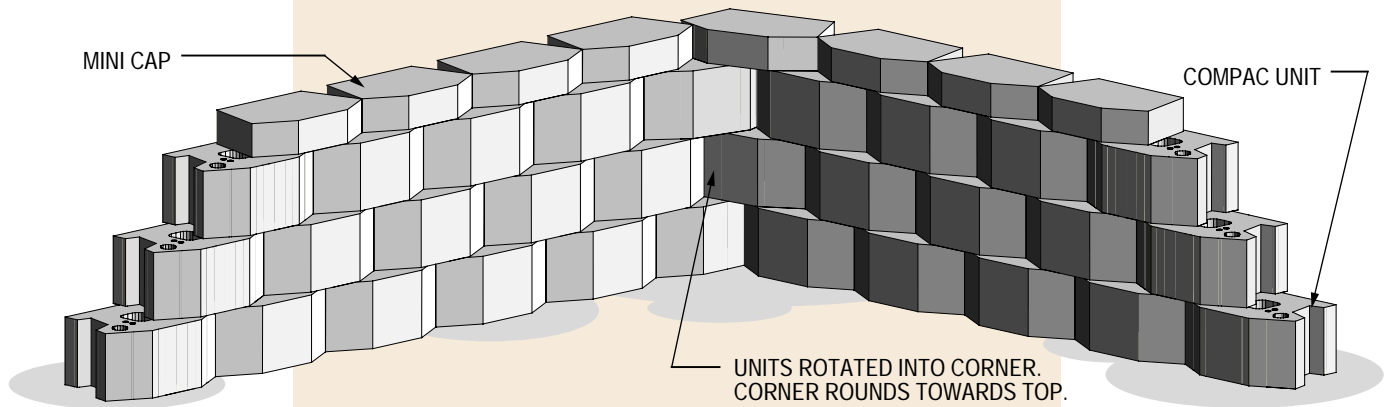

NOTE: All units shown with Sculptured Rock Face finish.

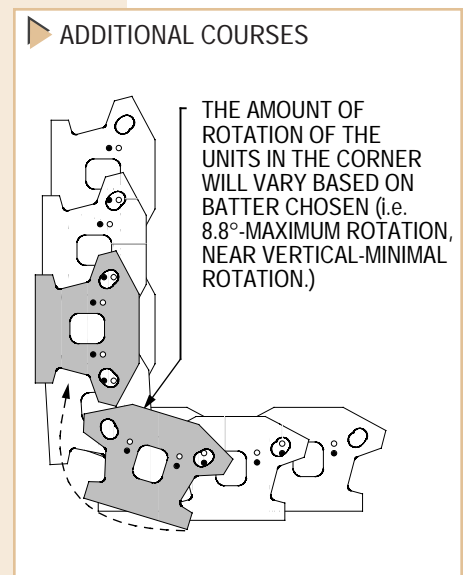
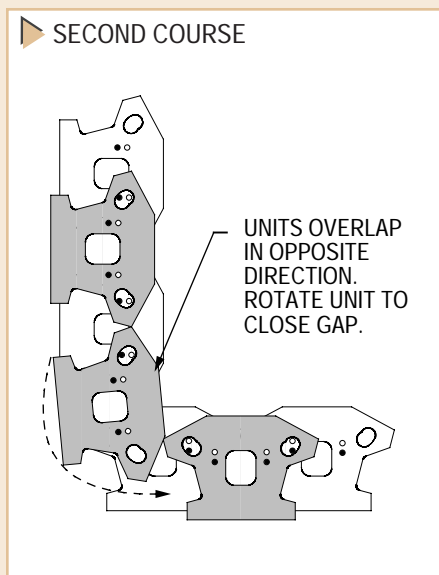
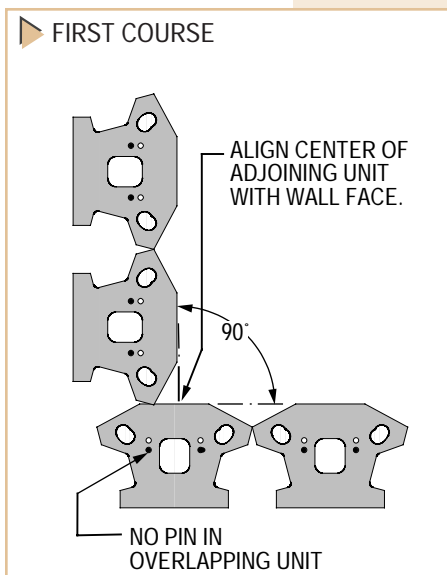

C O R N E R S A N D C U R V E S

▶ 90° INSIDE CORNER - SQUARED

The following information will provide a general explanation of construction techniques for building retaining walls with these conditions.

INSTALLATION PROCEDURES:

- ▶ Follow standard installation instructions for preparation of sub grade and leveling pad.
- ▶ Construction can start at the corner and work away from this point or with the method shown below, the wall can be started elsewhere and worked into the corner. This detail gives the builder flexibility.

QUESTION: How much should be cut off the first course as shown below?

ANSWER: A good place to start is approximately at the half unit range. This will result in field cutting the caps to finish the top of wall in the corner. If it is important to finish the wall with full cap units versus a cut unit as shown below, you will need to know how much setback occurs in your wall from base course to cap course to determine the starting location of the last full unit (uncut) at the base. To determine setback, follow this simple method: Place 3 units on a smooth level surface. Place fiberglass pins in desired setback option. Place next course of units in running bond pattern over base units. Pull upper unit forward towards face of wall. Now measure distance from tail surface of lower and upper courses. This is your setback dimension! Multiply this measurement times the total number of vertical courses. This will then give you the projected horizontal shift required to handle the setback of the two 90° walls away from the starting point.

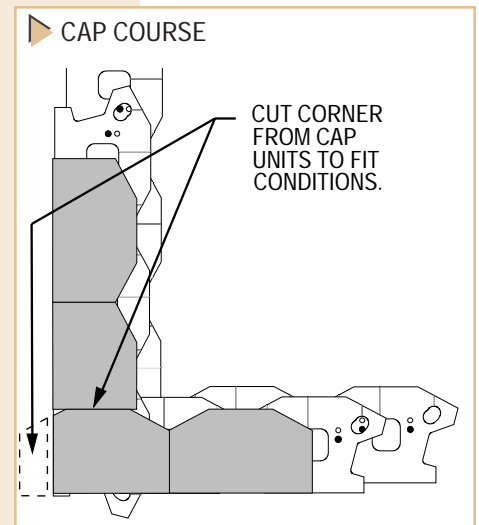
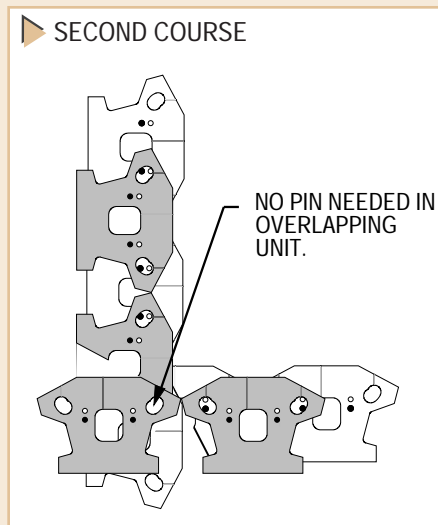
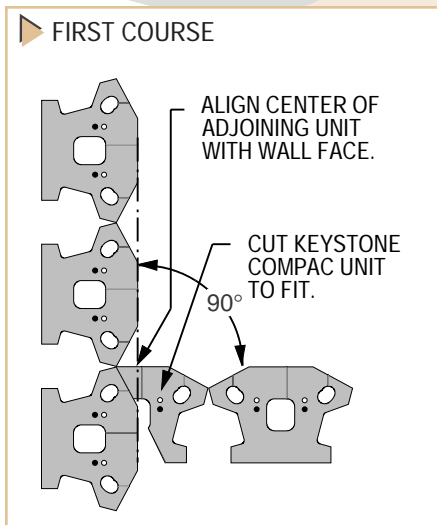
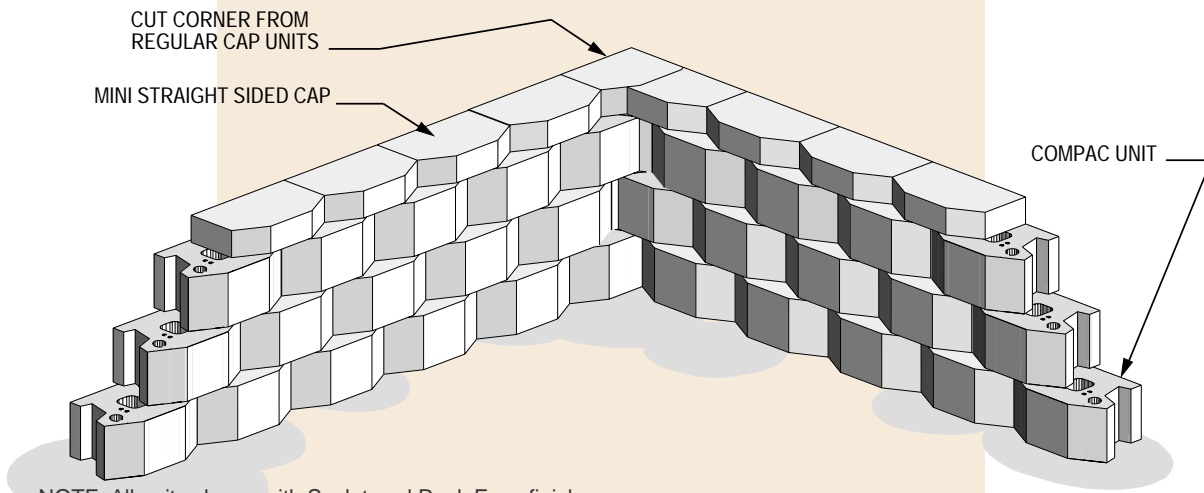

The information contained herein has been compiled by Keystone Retaining Wall Systems, Inc. and to the best of our knowledge, accurately represents the Keystone product use in the applications which are illustrated. Final determination of the suitability for the use contemplated and its manner of use are the sole responsibility of the user. Structural design and analysis shall be performed by a qualified engineer.
© 1997 KEYSTONE RETAINING WALL SYSTEMS, INC.
Minneapolis, Minnesota • (612) 897-1040 • (612) 897-3858-fax

C O R N E R S A N D C U R V E S

▶ 90° OUTSIDE CORNER - OPTION 1

No need to purchase special units for construction of these corners. The following information will provide a complete explanation of construction techniques for building retaining walls with a 90° corner using all Keystone® Unit types.

INSTALLATION PROCEDURES:

- ▶ Follow standard installation instructions for preparation of sub grade and leveling pad.
- ▶ Place units tight to each other. Corner Units will need to be cut to size for each course to maintain proper batter and alignment. The amount of modification is determined by the batter selection chosen (i.e. 8.8° batter will require the removal of more material than a near vertical batter). If Sculptured Rockface Units are being used, chip the corners off of the Corner Units to match the face pattern.
- ▶ Secure Corner with Keystone® Kapseal™ adhesive or other bonding agent, or by drilling pin holes in each adjoining unit.
- ▶ Follow standard installation instructions for back filling and placement of additional courses.
- ▶ If geogrid reinforcement is used, refer to manufacturers recommendations for proper placement of this material at corners.

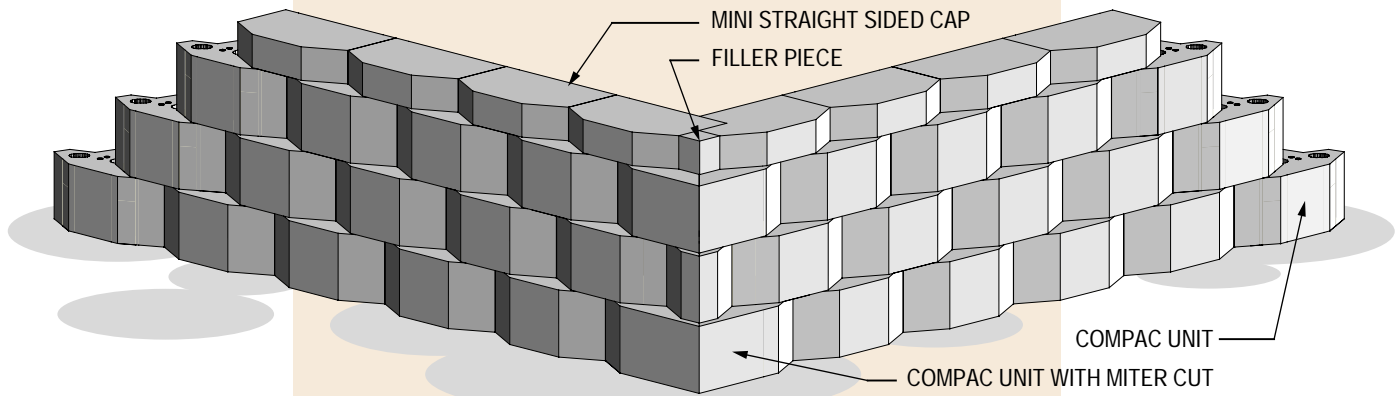

NOTE: All units shown with Sculptured Rock Face finish.

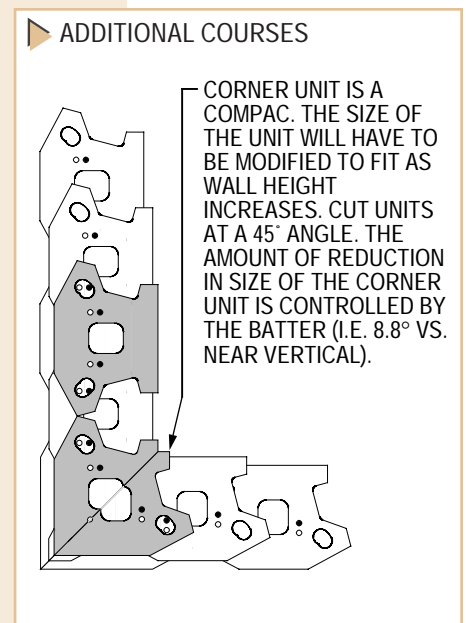
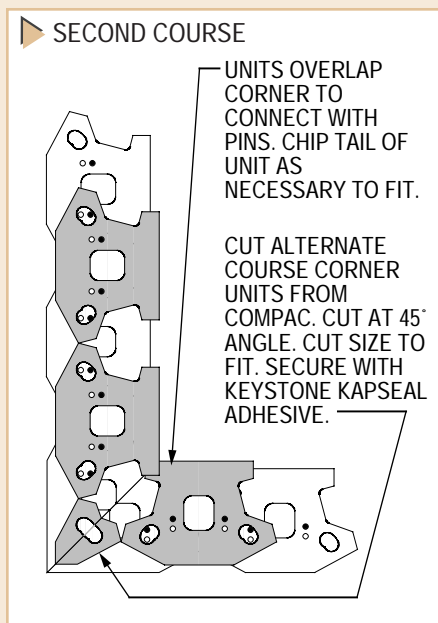
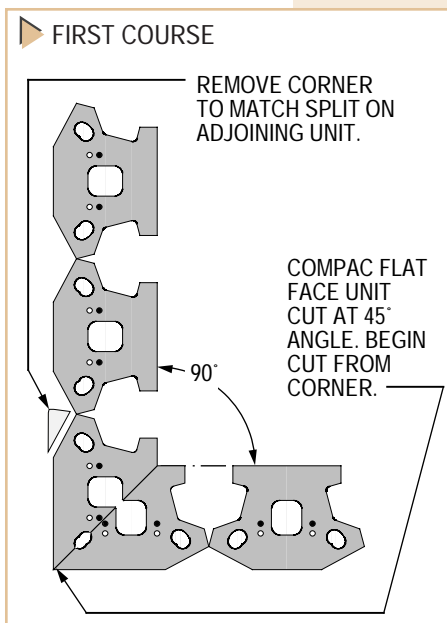

C O R N E R S A N D C U R V E S

▶ 90° OUTSIDE CORNER - OPTION 2

The following information will provide a complete explanation of construction techniques for building retaining walls using the 90° Corner Unit.

INSTALLATION PROCEDURES:

- ▶ Follow standard installation instructions for preparation of sub grade and leveling pad.
- ▶ Place units tight to each other. Corner Units will need to be cut to size for each course to maintain proper batter and alignment. The amount of modification is determined by the batter selection chosen (i.e. 8.8° batter will require the removal of more material than a near vertical batter). If Sculptured Rockface Unit are being used, chip the corners off of the Corner Units to match the face pattern.
- ▶ Secure corner with Keystone® Kapseal™ adhesive or other bonding agent, or by drilling pin holes in each adjoining unit.
- ▶ Follow standard installation instructions for back filling and placement of additional courses.
- ▶ If geogrid reinforcement is used, refer to manufacturers recommendations for proper placement of this material at corners.

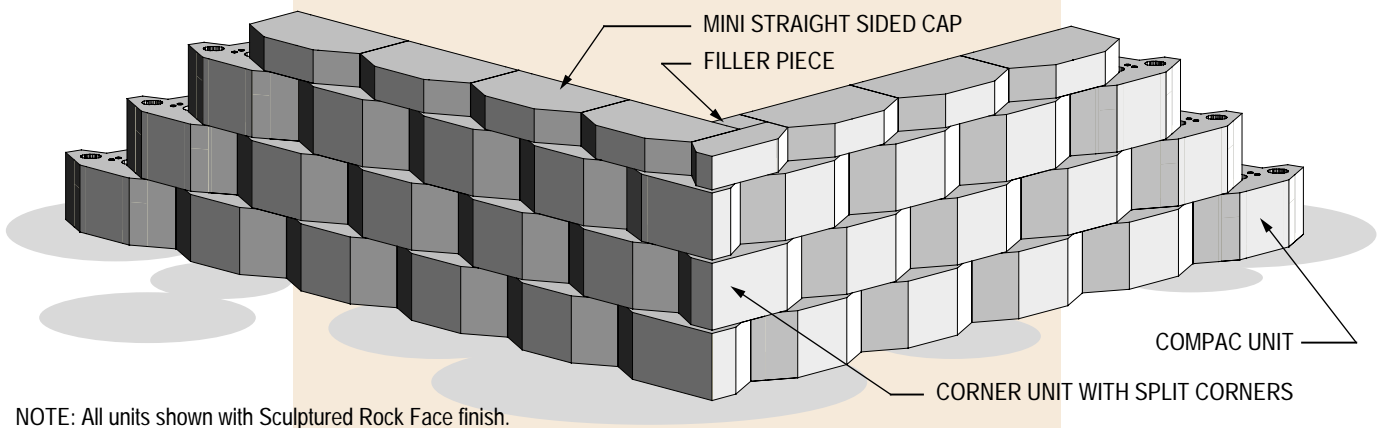

NOTE: All units shown with Sculptured Rock Face finish.

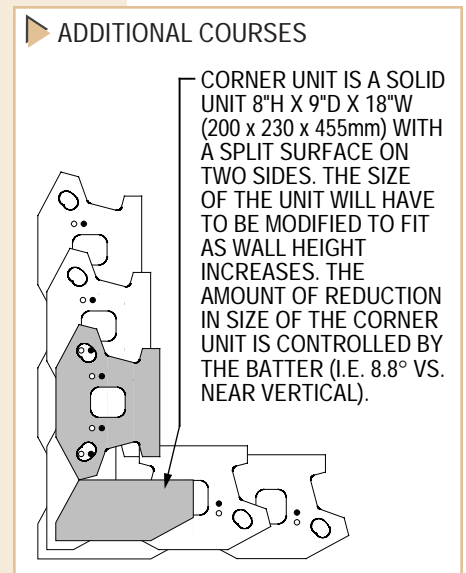
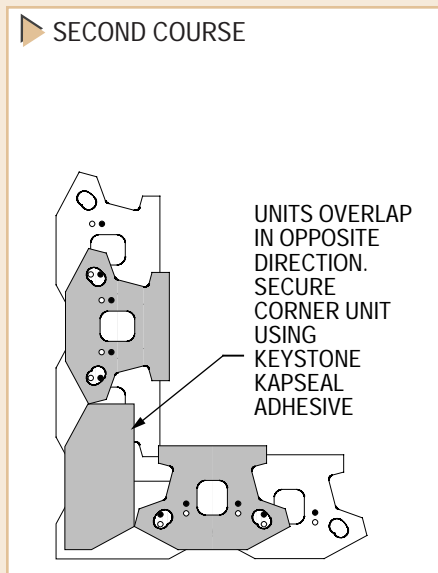
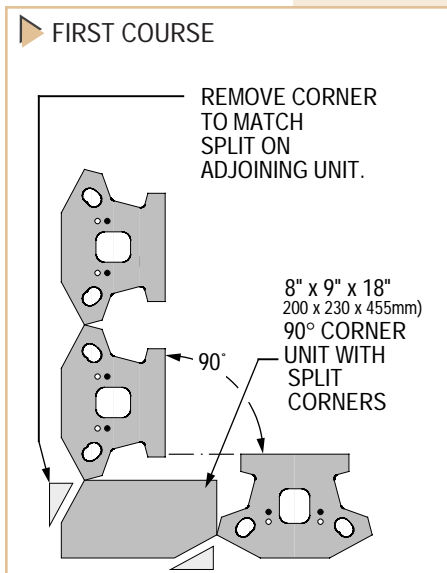

The information contained herein has been compiled by Keystone® Retaining Wall Systems, Inc. and to the best of our knowledge, accurately represents the Keystone product use in the applications which are illustrated. Final determination of the suitability for the use contemplated and its manner of use are the sole responsibility of the user. Structural design and analysis shall be performed by a qualified engineer.
© 1997 KEYSTONE RETAINING WALL SYSTEMS, INC.
Minneapolis, Minnesota • (612) 897-1040 • (612) 897-3858-fax

C O R N E R S A N D C U R V E S

▶ 135° OUTSIDE CORNER OPTION

The following information will provide a general explanation of construction techniques for building retaining walls with a 135° corner angle using Standard or Compac Keystone® Unit types.

INSTALLATION PROCEDURES:

- ▶ Follow standard installation instructions for preparation of sub grade and leveling pad.
- ▶ Place units tight to each other. Corner Units will need to be cut to size for each course to maintain proper alignment. The amount of modification is determined by the batter selection chosen. In “near vertical” setback position, amount of cutting of units should be similar for all courses. With full setback position, each successive course will require greater and greater removal of material at the corner unit.
- ▶ Secure corner with Keystone® Kapseal™ adhesive or other bonding agent.
- ▶ Follow standard installation instructions for back filling and placement of additional courses.
- ▶ If geogrid reinforcement is used, refer to manufacturers recommendations for proper placement of this material along curves corners.

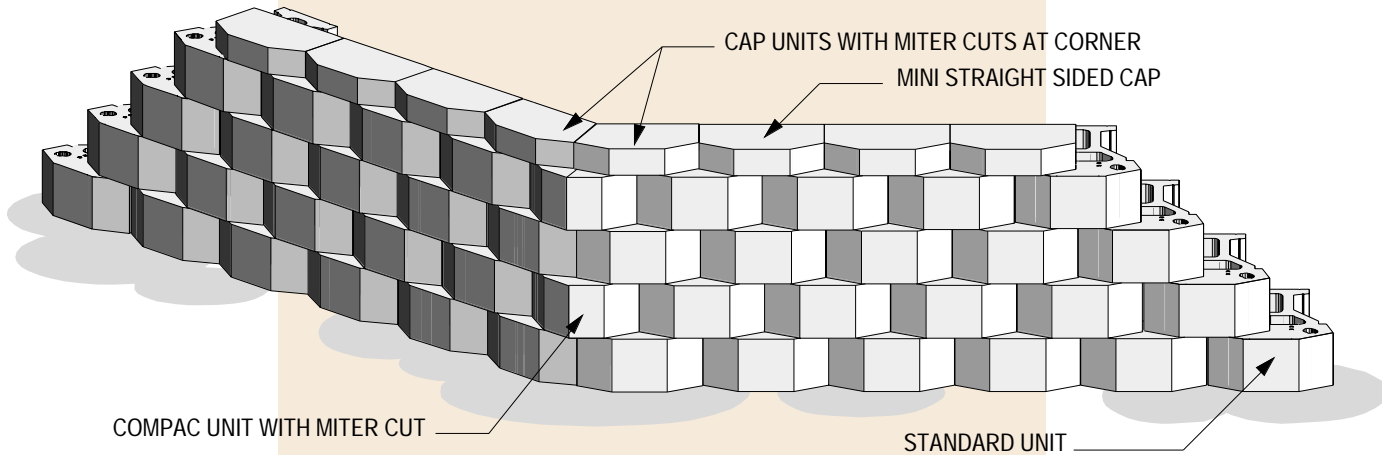

NOTE: All units shown with Sculptured Rock Face finish.

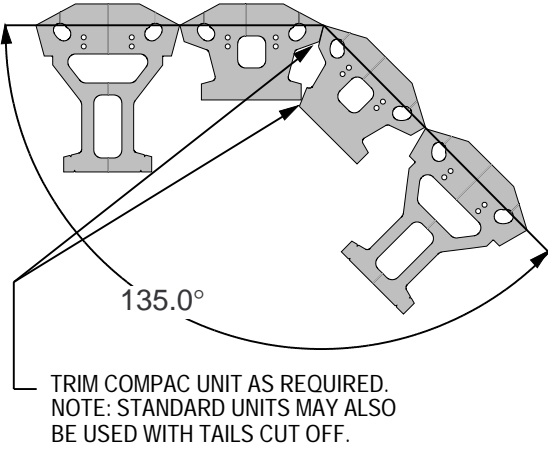
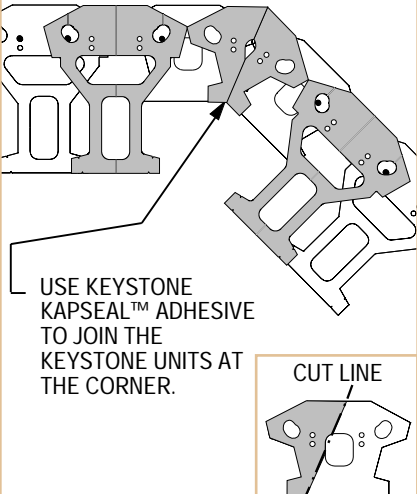
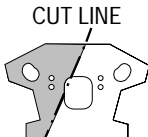
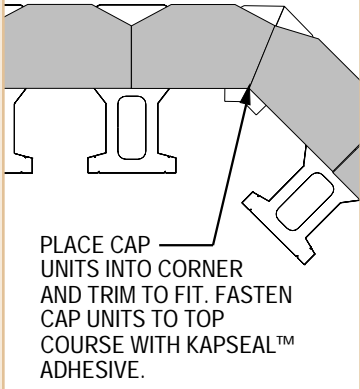
▶ FIRST COURSE	▶ SECOND COURSE	▶ CAP COURSE
 <p>135.0°</p> <p>TRIM COMPAC UNIT AS REQUIRED. NOTE: STANDARD UNITS MAY ALSO BE USED WITH TAILS CUT OFF.</p>	 <p>USE KEYSTONE KAPSEAL™ ADHESIVE TO JOIN THE KEYSTONE UNITS AT THE CORNER.</p>  <p>CUT LINE</p>	 <p>PLACE CAP UNITS INTO CORNER AND TRIM TO FIT. FASTEN CAP UNITS TO TOP COURSE WITH KAPSEAL™ ADHESIVE.</p>

The information contained herein has been compiled by Keystone® Retaining Wall Systems, Inc. and to the best of our knowledge, accurately represents the Keystone product use in the applications which are illustrated. Final determination of the suitability for the use contemplated and its manner of use are the sole responsibility of the user. Structural design and analysis shall be performed by a qualified engineer.
© 1997 KEYSTONE RETAINING WALL SYSTEMS, INC.
Minneapolis, Minnesota • (612) 897-1040 • (612) 897-3858-fax