

# STEPS AND STAIRS

- ▶ Steps And Stairs Installation
- ▶ Option 1 - Steps In Wall
- ▶ Option 2 - Steps With Plant Space
- ▶ Option 3 - Steps In Front of Walls
- ▶ Option 4 - Steps Along Wall Face
- ▶ Option 5 - Steps In Wall; 10" (25cm) Tread
- ▶ Option 6 - Steps In Wall; 18" (46cm) Tread
- ▶ Option 7 - Step Parallel to Wall

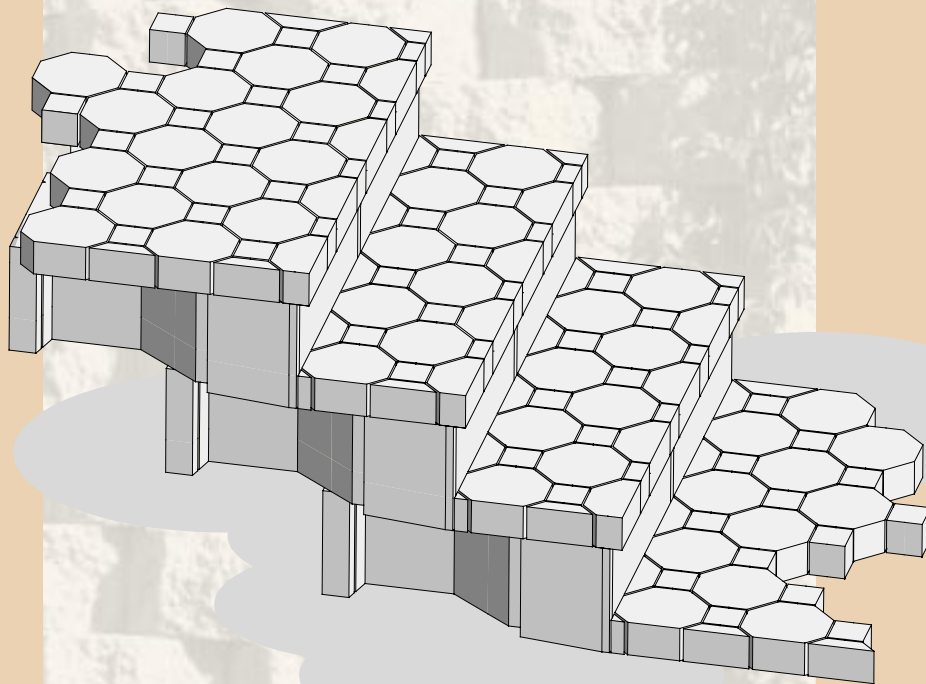

STEPS AND STAIRS

▶ STEPS & STAIRS INSTALLATION

The Keystone® Retaining Wall System not only provides a great deal of flexibility in wall construction but also in step design. Steps and stairs can be customized to fit a variety of applications. This document will discuss the various placement options available, surface materials and installation procedures for construction of steps and stairs using the Keystone® units. Steps can either be constructed prior to construction, while construction is underway or after construction is complete. This means that no matter the state of a particular site, steps and (or) a Keystone® Retaining Wall can be built without a great deal of complication. Each step illustration can be built independent of the adjoining retaining wall if none is required. Steps and stairs of other materials (i.e. poured concrete, natural stone) can be integrated successfully with a Keystone® wall in lieu of the step illustrations shown. Steps constructed using Keystone® units are not recommended for high traffic usage (i.e. commercial installations). All illustrations demonstrate the most popular methods currently used for step construction. Steps are shown with a 36"x10"-13" (915 x 255 - 330mm) wide tread and an 8" (200mm) riser. Other dimension combinations are possible and will be discussed later in this document. Step risers are shown as Keystone® Standard Straight Face Units. Sculptured Rock Face units may also be used. The flexibility of Keystone® allows for further design options. The following is a list of tools and supplies that may be necessary when building Keystone® steps:

- Square and round nosed shovels
- Compactor (hand and/or power)
- Level-3' (1m) or wider
- Rubber or small sledge hammer
- Tape measure
- 3" - 4" (75 - 100mm) backset/chisel
- Concrete saw
- Caulking gun
- Broom
- Keystone® Kapseal™

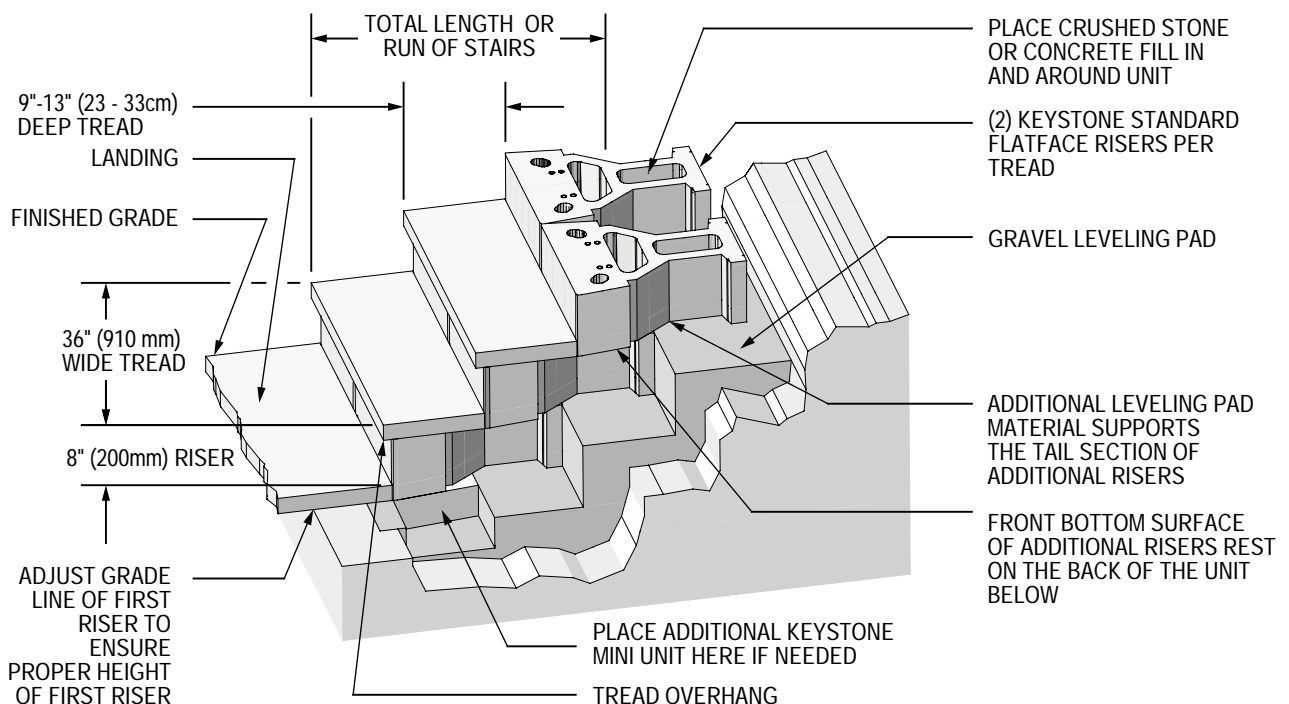

# STEPS AND STAIRS

## ▶ STEPS & STAIRS INSTALLATION

Follow these step by step procedures for a successful residential installation of Keystone® steps and stairs. Refer to STEP OPTIONS 1 thru 7 for more detail.

- ▶ **STEP 1: DETERMINE WHICH TYPE OF STEP AND STAIR MATERIAL WILL BE USED** (See STEP 14 for tread material options)
- ▶ **STEP 2: SPECIFY THE WIDTH OF STEPS**  
When using the Keystone® units, various incremental dimensions are possible without unit modification. Each Keystone® unit is 18" (457mm) wide. A multiple of this equals step widths of 36"(0.9m), 54" (1.4m), 72"(1.8m) (etc. Additional width should be added if a planting space will be provided between the sides of the steps and the retaining wall (see Option 2).
- ▶ **STEP 3: CALCULATE THE HEIGHT OF THE RISER AND THE DEPTH OF THE TREAD**  
Most municipal building departments have code requirements regarding dimensions for steps and stairs used in site construction. CHECK WITH LOCAL OFFICIALS FOR REQUIREMENTS. If the steps and stairs will be built using the Keystone® units, use the height of a Keystone® unit (8"H) (200mm) as the standard riser dimension. Any uniformly dimensioned tread material placed on top of the Keystone® risers will maintain the 8" (200mm) riser dimension. Step tread dimensions should be 9"-13" (25-35mm) wide . (General rule for exterior stairs: 2 risers + tread = 26" (660mm). If step landings will be used instead of stairs, tread dimensions should be multiples of 18" (457mm) (i.e. 36" (915mm), 54" (1.4m)) for comfortable passage from one landing to another.

**QUESTION:** How do I calculate how many steps will be needed to scale a specific grade?

**ANSWER:** Total height of the slope ÷ 8"(200mm) (Keystone® riser height) = Number of risers (round to the nearest full riser)

**EXAMPLE:** 12' ÷ 8" (.67') = 18 risers (0.305m x 18 = 5.5m)

**QUESTION:** How do I calculate the distance the steps will travel into the embankment?

**ANSWER:** Tread width x Number of risers = Total length of stairs

**EXAMPLE:** 12" x 18 = 216" (18') (0.305m x 18 = 5.5m)

- ▶ **STEP 4: LAY OUT WALL AND STEP LOCATION**  
Taking the above calculations into account, design and lay out where steps are to be located.
- ▶ **STEP 5: EXCAVATE THE BASE TRENCH FOR PLACEMENT OF THE FIRST KEYSTONE® RISER UNITS**  
If the steps and stairs are being built adjoining a Keystone Retaining Wall, use the same grade lines as used for the wall so that the horizontal plane of the step and wall units align. If not, excavate the Base Trench to a depth that will allow placement of a 6" (150mm) Base Leveling Pad. The finished grade of the Base Leveling Pad should be on the same grade line as the bottom of the landing material (typically the same material used as tread surfaces). This will ensure that the rise of the first step will be the same as the remaining steps. If no landing material will be used (i.e. steps from a gravel walk or a grass lawn), an additional Keystone® Mini Unit will need to be placed below the first Keystone® riser. This provides the necessary interlock with the soil at the base of the steps. Join the First riser and the Mini Unit using the same bonding procedures recommended for attaching the treads (STEP 14). Keystone® pins are not used to join the units since they will be stacked directly above one another instead of the normal running bond pattern.
- ▶ **STEP 6: PLACE AND COMPACT THE BASE LEVELING PAD MATERIAL**  
This should be the same material as used in Keystone® Retaining Wall construction. See STEP 2 of INSTALLATION STEP BY STEP for further detail. Level the Base Leveling Pad with a square nosed shovel left to right and front to back. Hand or machine compact this material to 95% of Standard Proctor (95% of the soil's maximum density).

STEPS AND STAIRS

▶ STEPS & STAIRS INSTALLATION

- ▶ **STEP 7: SET THE FIRST KEYSTONE® RISER**  
Stability is as important an issue for steps as it is for retaining walls. For this reason, the Keystone® Standard Unit is recommended for use as the step riser. Its proportional height to width ratio (8"H x 18"W x 21-1/2"D) (200 x 457 x 545mm) creates a stable platform. Its depth provides a solid platform for placement of additional step risers. Position and align the first Keystone® risers.
- ▶ **STEP 8: POSITION RETAINING WALL UNITS IF APPLICABLE**  
If a Keystone® Retaining Wall is adjoining the steps and stairs, position and align the units on the same course as the first step. For specific details, see STEP OPTIONS 1 THRU 7.
- ▶ **STEP 9: PLACE UNIT FILL MATERIAL**  
If units will be back filled with concrete, skip to the next step (see placement of tread material for a complete explanation). If not, fill in and around units with Drainage Backfill Material (3/8"-3/4" (10-20mm) crushed stone). Gently compact this material to permanently position the first Keystone® risers.
- ▶ **STEP 10: POSITION THE NEXT KEYSTONE RISER**  
Having determined the depth of the tread, measure this dimension from the face of the first riser back to the face of the second riser. Mark a line for position. If the tread will overhang the front of the riser, move the position of the second riser forward the overhang dimension. The front surface of the second step will rest firmly on the risers below them. The tail section of these units will be supported on grade. Level and prepare this material using the same procedures as in STEP 6.
- ▶ **STEP 11: REPEAT BACKFILL PROCEDURES**  
Backfill in and around the Keystone® riser as in STEP 9 to fix the position of the units. To eliminate potential movement caused by placement of succeeding risers during backfill and construction, join units using the same bonding procedures recommended for attaching treads (STEP 14).
- ▶ **STEP 12: CONTINUE WITH STEPS 9 & 10 UNTIL ALL RISERS ARE IN PLACE**
- ▶ **STEP 13: PLACE CONCRETE FILL**  
If Keystone® risers will be filled with concrete, backfill with this material at this time. Filling units with concrete joins all Keystone® step risers into one monolithic structure. Concrete passes between units joining them to each other.
- ▶ **STEP 14: APPLY TREAD MATERIAL**  
Most tread materials can be used with Keystone® units. Step treads are attached using Keystone® Kapseal™ adhesive, mortar or epoxy adhesive. A monolithic concrete tread should be poured at the same time units are filled. This interlocks the tread with the Keystone® unit. If a 1/2"-3/4" (15-20mm) concrete skim coat is used as the step tread, use a concrete additive to reduce cracking and chipping. When using manufactured treads (i.e. pavers), consult the supplier or a masonry dealer for specific bonding material recommendations.

▶ FORMED AND POURED CONCRETE SLAB

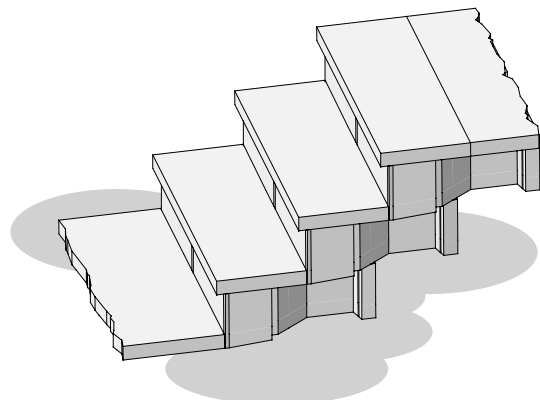

STEPS AND STAIRS

▶ STEPS & STAIRS INSTALLATION

▶ CONCRETE SKIM COAT (1/2" - 3/4") (15 -20mm)

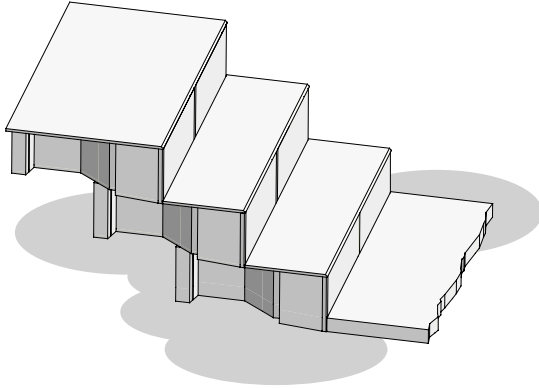

▶ PATIO PAVERS (12" x 12") (305 x 305mm)

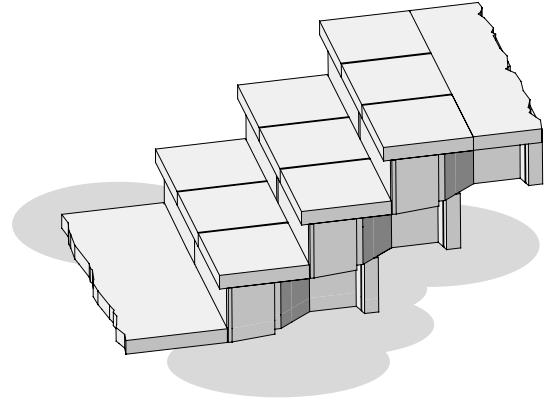

▶ MINI FLAT FACE STRAIGHT SIDE CAP UNIT

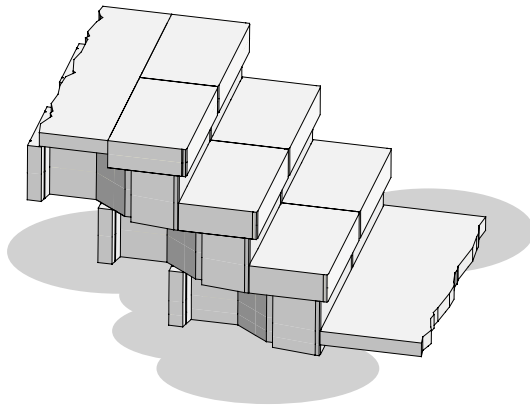

▶ NATURAL FIELD STONE

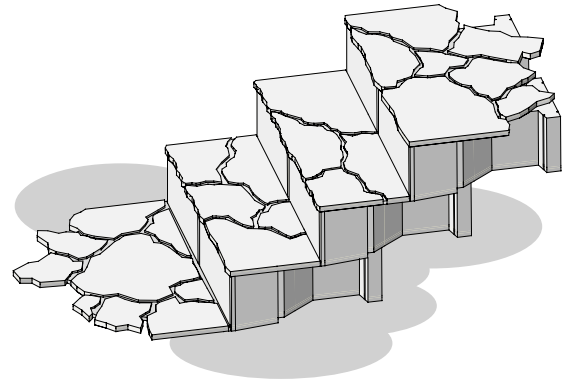

▶ MINI CAP WITH PLANTING SPACES

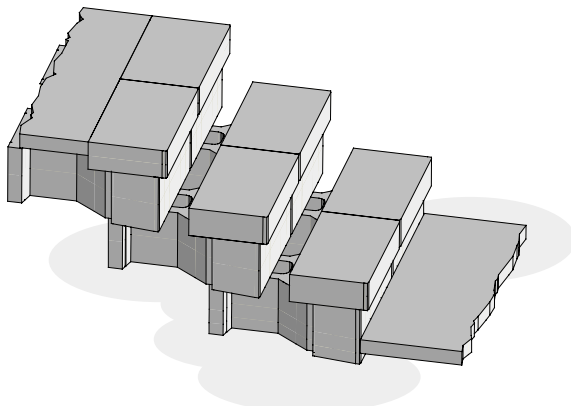

▶ BRICK OR CONCRETE PAVERS

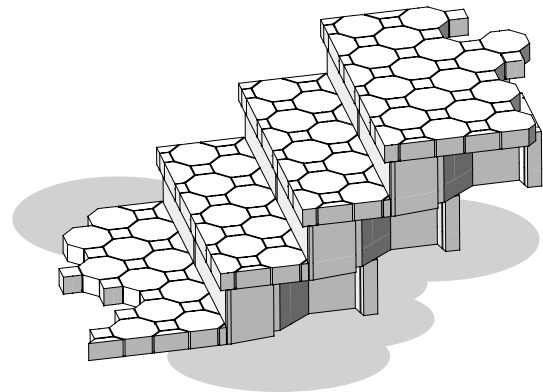

STEPS AND STAIRS

▶ OPTION 1 - STEPS IN WALL

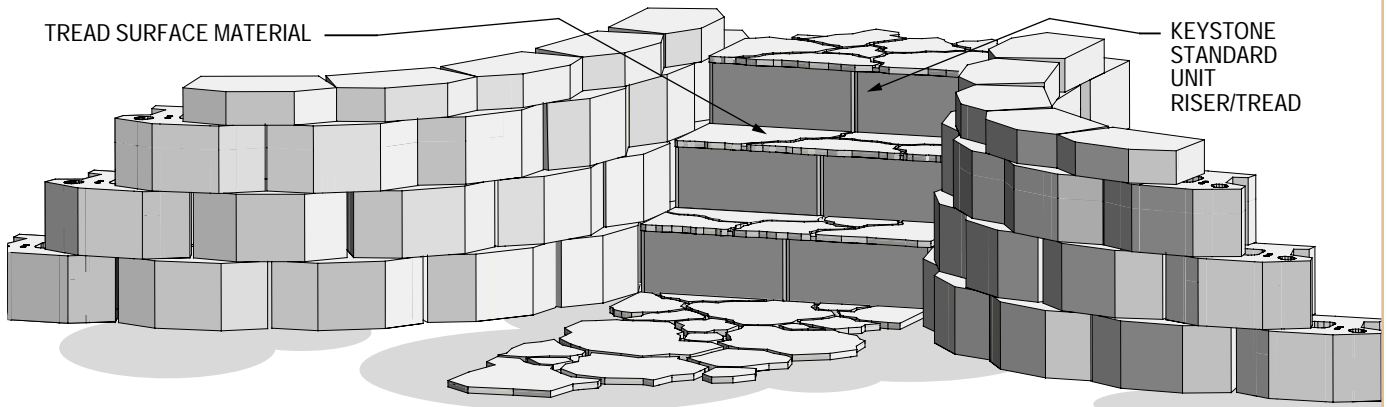

NOTES: All wall units shown with Sculptured Rock Face finish. All step risers shown with a Flat Face finish. Tread shown with a flagstone finish.

▶ **FIRST COURSE**

KEYSTONE STANDARD UNIT RISER/TREAD

RADIUS CURVE. 90° CORNER OPTIONAL

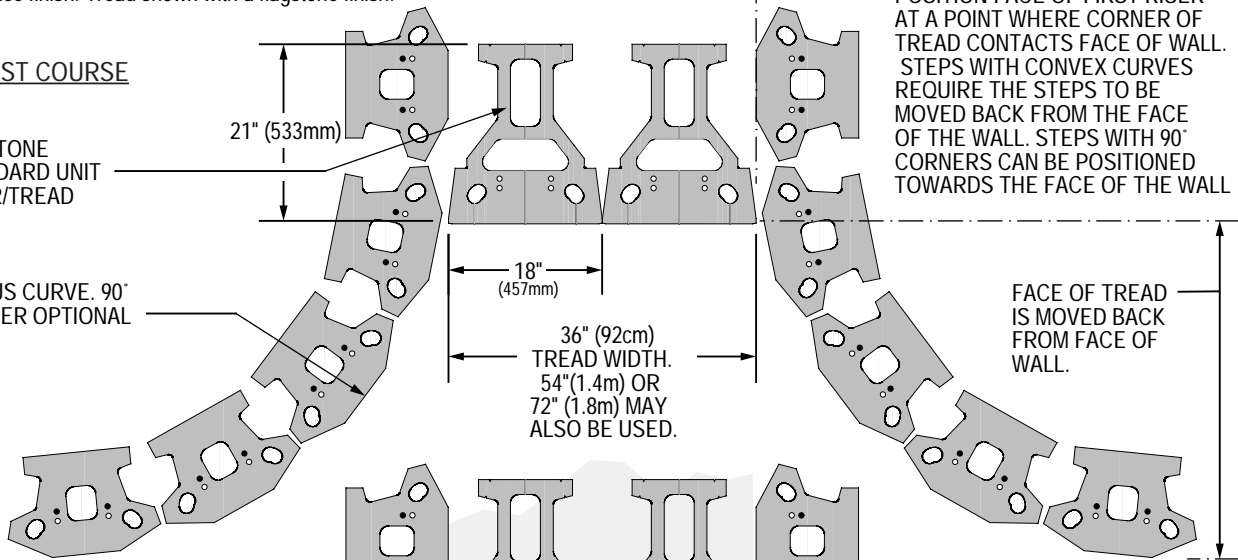

POSITION FACE OF FIRST RISER AT A POINT WHERE CORNER OF TREAD CONTACTS FACE OF WALL. STEPS WITH CONVEX CURVES REQUIRE THE STEPS TO BE MOVED BACK FROM THE FACE OF THE WALL. STEPS WITH 90° CORNERS CAN BE POSITIONED TOWARDS THE FACE OF THE WALL

FACE OF TREAD IS MOVED BACK FROM FACE OF WALL.

▶ **SECOND COURSE**

SLIDE UNITS FORWARD TO CONTACT SIDE OF RISER, CLOSING GAPS. AMOUNT OF ADJUSTMENT REQUIRED IS CONTROLLED BY THE BATTER OPTION USED (i.e. 8.8° BATTER REQUIRES MORE ADJUSTMENT THAN A NEAR VERTICAL BATTER).

FILL AROUND UNITS

KEYSTONE RISER/TREAD. APPLY TREAD SURFACE MATERIAL TO THIS AREA

PLACEMENT OF ADDITIONAL RISER/TREADS OVER UNITS BELOW

10-13" (25-33cm) TREAD WIDTH

STEPS AND STAIRS

▶ OPTION 2 - STEPS WITH PLANT SPACE

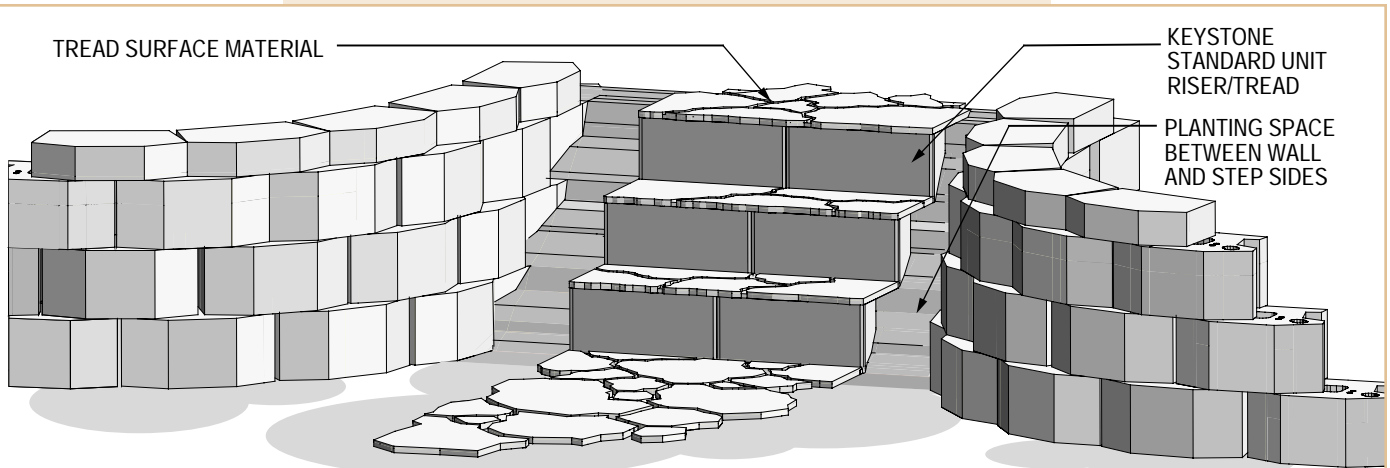

NOTES: All wall units shown with Sculptured Rock Face finish. All step risers shown with a Flat Face finish. Tread shown with a flagstone finish.

▶ FIRST COURSE

KEYSTONE STANDARD UNIT RISER/TREAD

RADIUS CURVE. 90° CORNER OPTIONAL

21" (53cm)

18" (457mm)

36" (92cm)  
TREAD WIDTH

PLANTING SPACE. VARIABLE DIMENSION

FACE OF TREAD IS MOVED BACK FROM FACE OF WALL. THIS IS NOT A FIXED POSITION. A GREATER OR LESSER DEPTH IS ACCEPTABLE.

▶ SECOND COURSE

INSTALL RETAINING WALL UNITS USING PRESCRIBED PROCEDURES. NO SPECIAL ADJUSTMENTS REQUIRED.

PLANTING SPACE

FILL AROUND UNITS

KEYSTONE RISER/TREAD. APPLY TREAD SURFACE MATERIAL TO THIS AREA

PLACEMENT OF ADDITIONAL RISER/TREADS OVER UNITS BELOW

10-13" (25 - 35cm)  
TREAD WIDTH

STEPS AND STAIRS

▶ OPTION 3 - STEPS IN FRONT OF WALLS

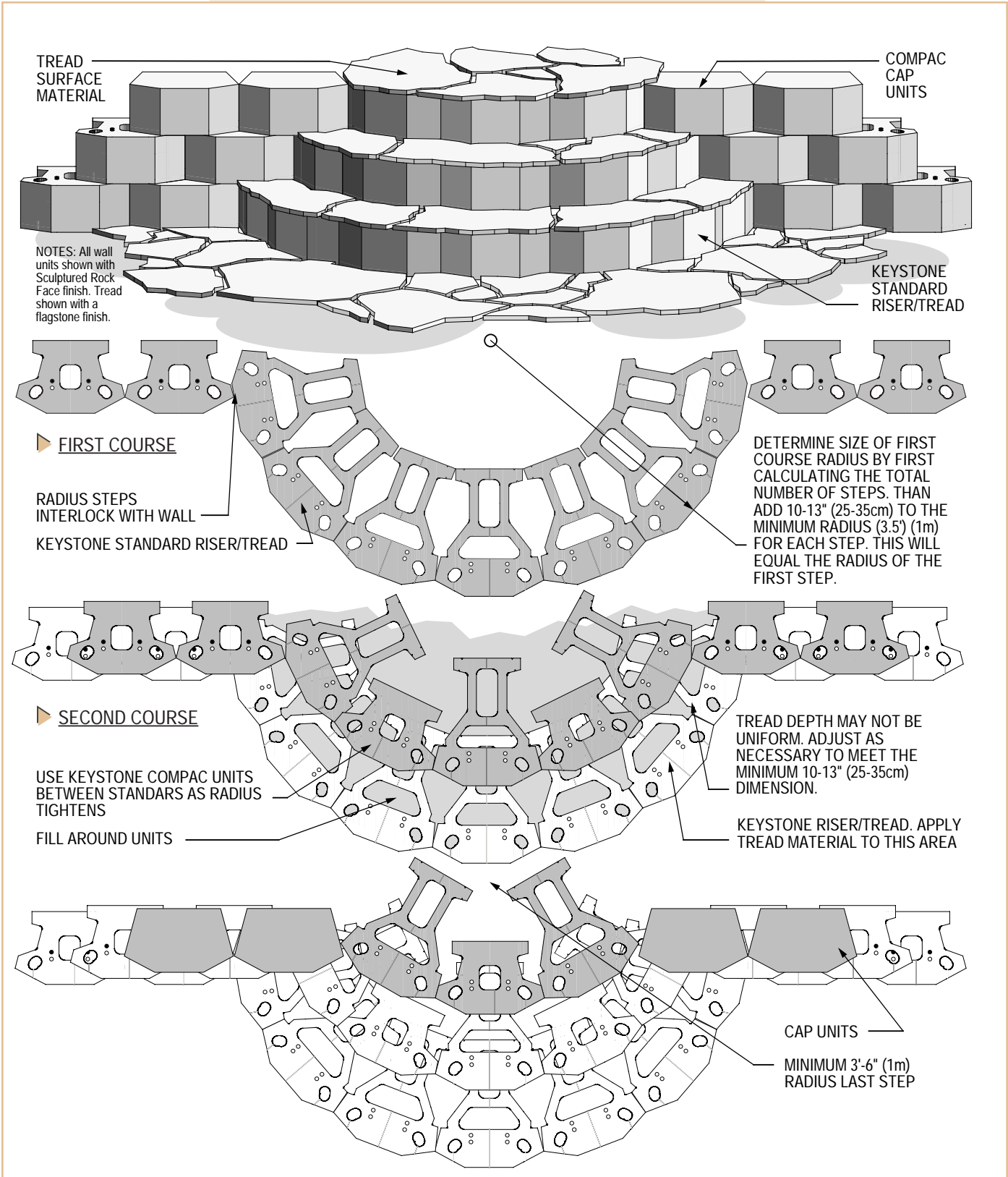

The information contained herein has been compiled by Keystone Retaining Wall Systems, Inc. and to the best of our knowledge, accurately represents the Keystone product use in the applications which are illustrated. Final determination of the suitability for the use contemplated and its manner of use are the sole responsibility of the user. Structural design and analysis shall be performed by a qualified engineer.  
© 1997 KEYSTONE RETAINING WALL SYSTEMS, INC.  
Minneapolis, Minnesota • (612) 897-1040 • (612) 897-3858-fax



STEPS AND STAIRS

▶ OPTION 4 - STEPS ALONG WALL FACE

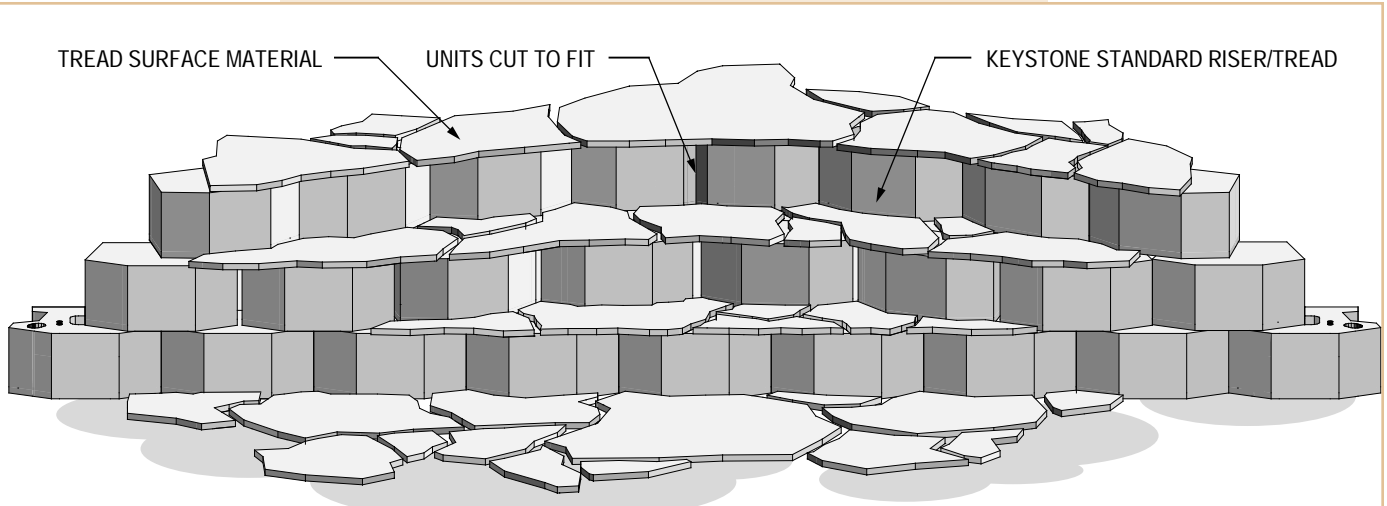

NOTES: All wall units shown with Sculptured Rock Face finish. Tread shown with a flagstone finish.

▶ FIRST COURSE

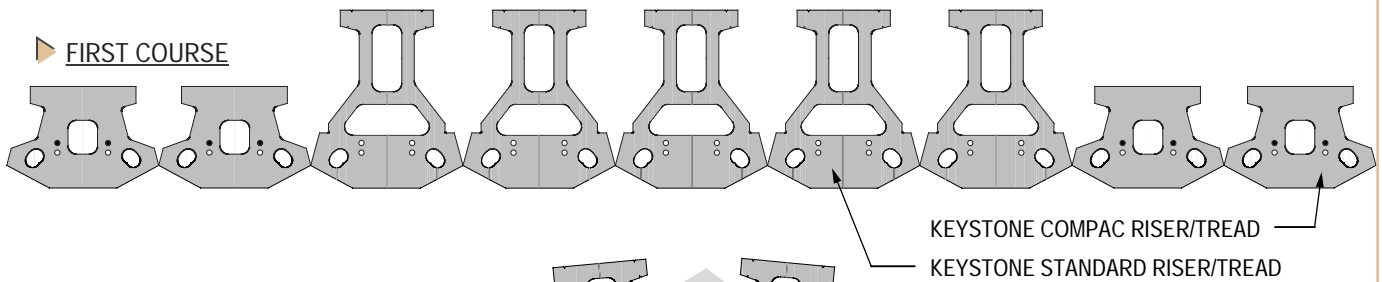

▶ SECOND COURSE

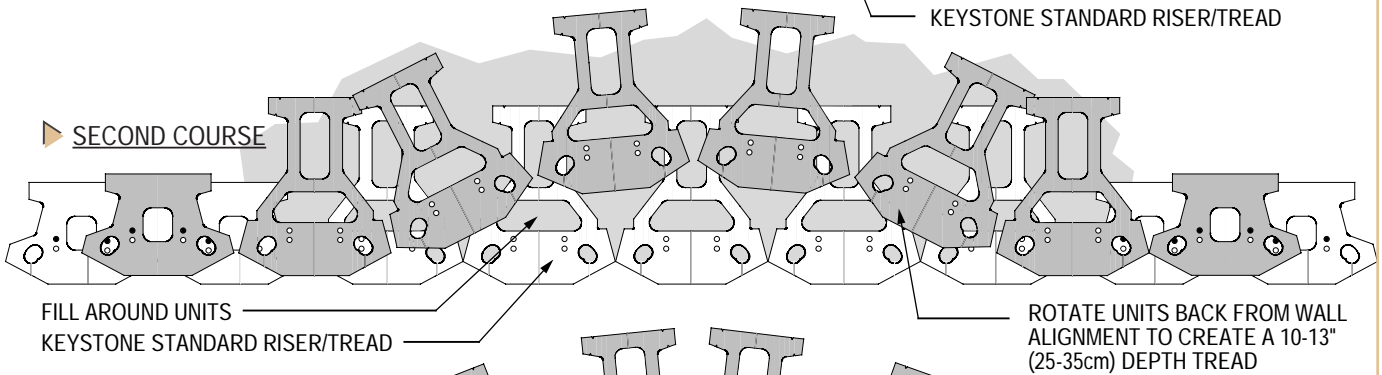

▶ THIRD COURSE

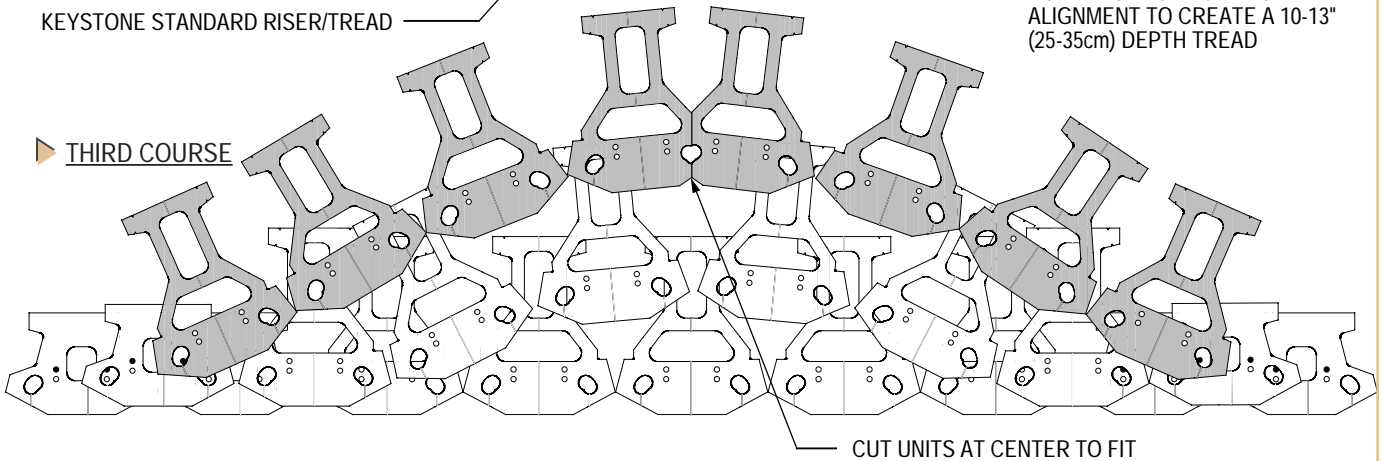

STEPS AND STAIRS

▶ OPTION 5 - STEPS IN WALL; 10" TREAD

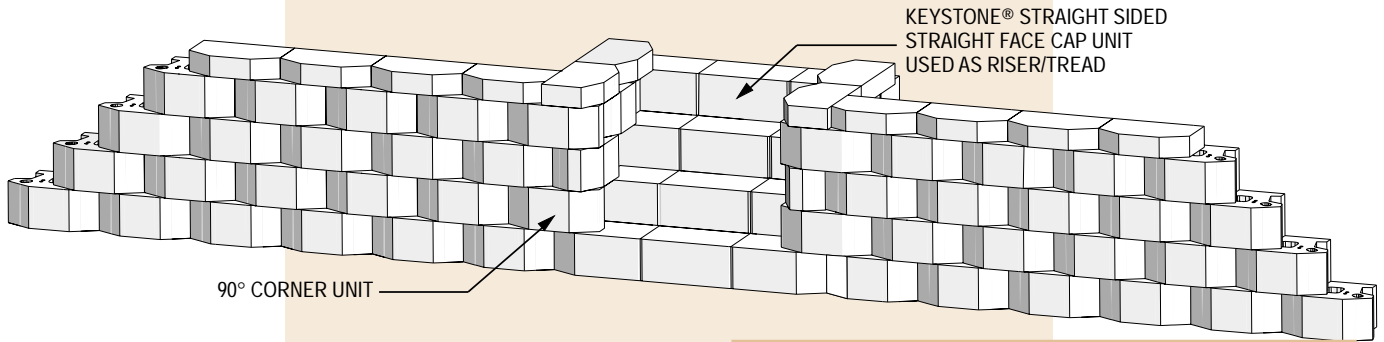

▶ 10" (25cm) TREAD DEPTH

NOTE: All wall units shown with sculptured Rock Face finish.

CORNER UNITS MAY BE CORED OR SOLID. CHECK WITH YOUR LOCAL DISTRIBUTOR FOR PRODUCT AVAILABILITY.

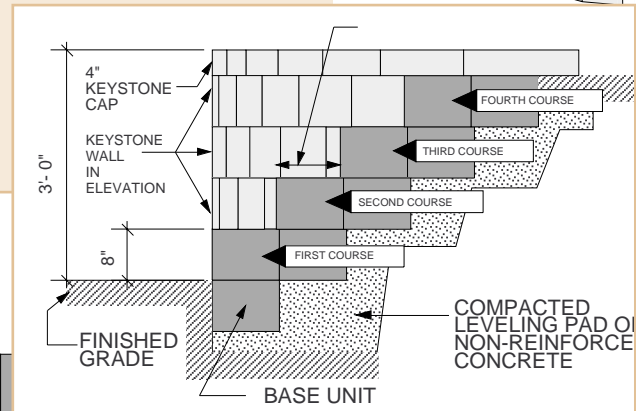

▶ FOURTH COURSE

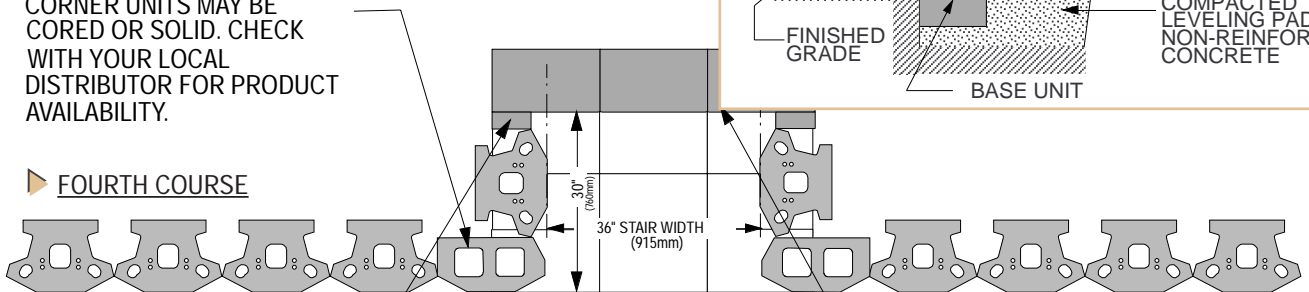

CUT SHIM PIECE TO FIT

▶ THIRD COURSE

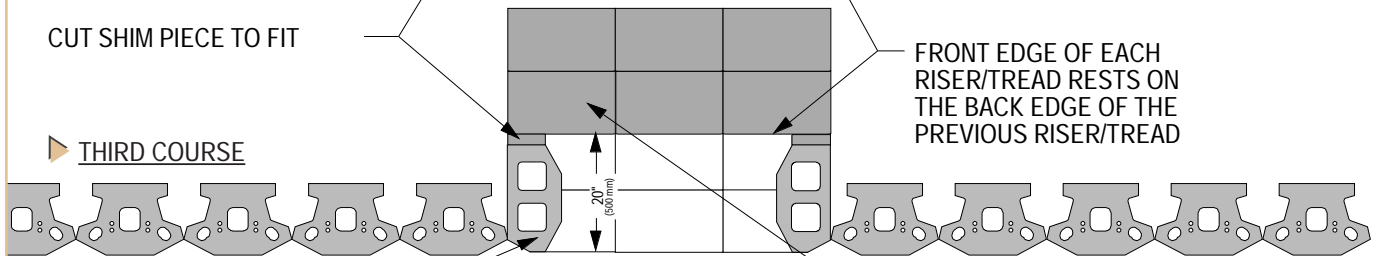

9" DEEP 90° CORNER UNIT (230mm)

▶ SECOND COURSE

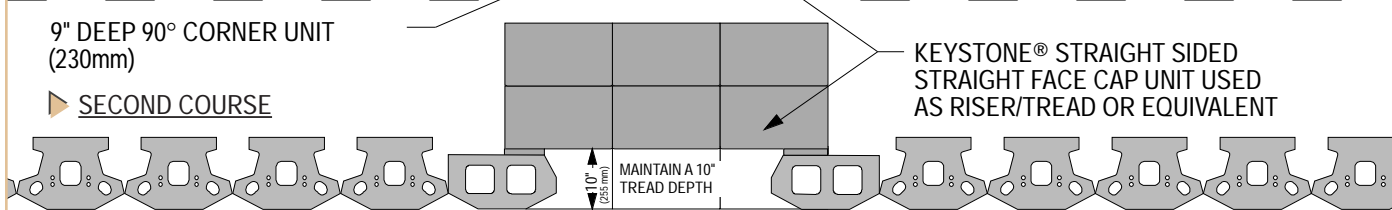

▶ FIRST COURSE

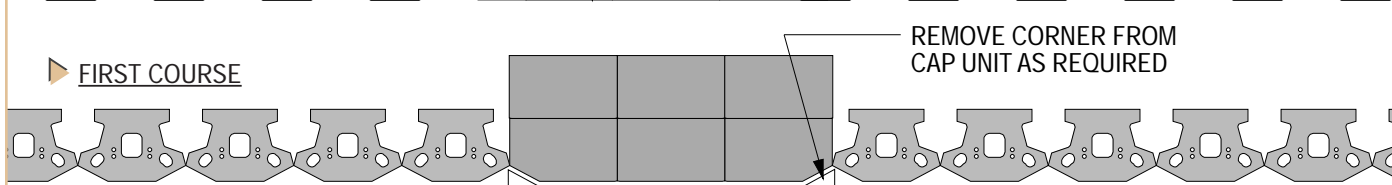

The information contained herein has been compiled by Keystone® Retaining Wall Systems, Inc. and to the best of our knowledge, accurately represents the Keystone product use in the applications which are illustrated. Final determination of the suitability for the use contemplated and its manner of use are the sole responsibility of the user. Structural design and analysis shall be performed by a qualified engineer.  
© 1997 KEYSTONE RETAINING WALL SYSTEMS, INC.  
Minneapolis, Minnesota • (612) 897-1040 • (612) 897-3858-fax

STEPS AND STAIRS

▶ OPTION 6 - STEPS IN WALL; 18" TREAD

▶ 18" (46cm) TREAD DEPTH

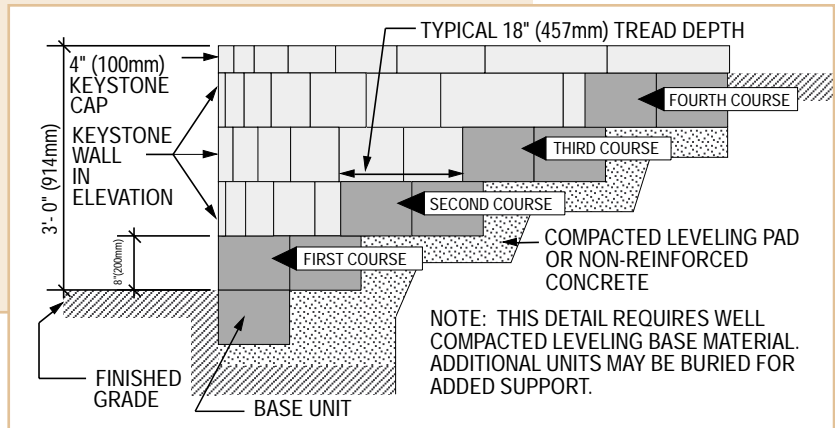

NOTE: Corner units may be cored or solid. Check with your local distributor for product availability.

▶ FOURTH COURSE

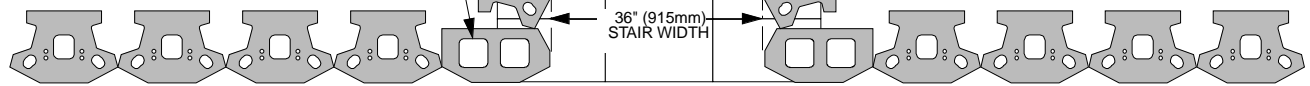

KEYSTONE® STRAIGHT SIDED STRAIGHT FACE CAP UNIT USED TO DOUBLE TREAD DEPTH

9" DEEP 90° CORNER UNIT (230mm)

▶ THIRD COURSE

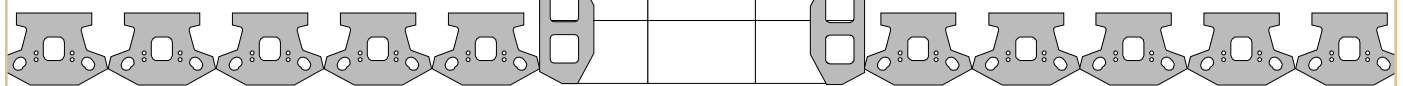

CUT UNITS TO FIT RETURN

▶ SECOND COURSE

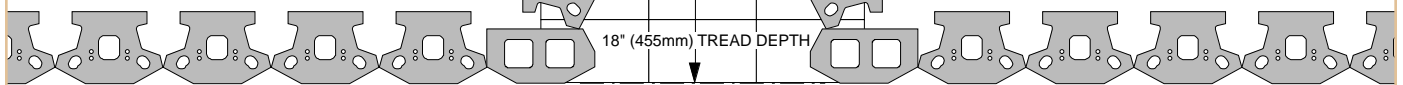

18" (457mm) TREAD DEPTH

▶ FIRST COURSE

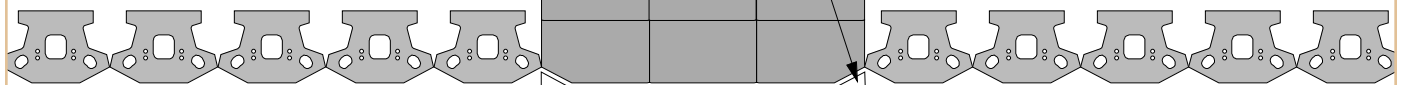

STEPS AND STAIRS

▶ OPTION 7 - STEP PARALLEL TO WALL

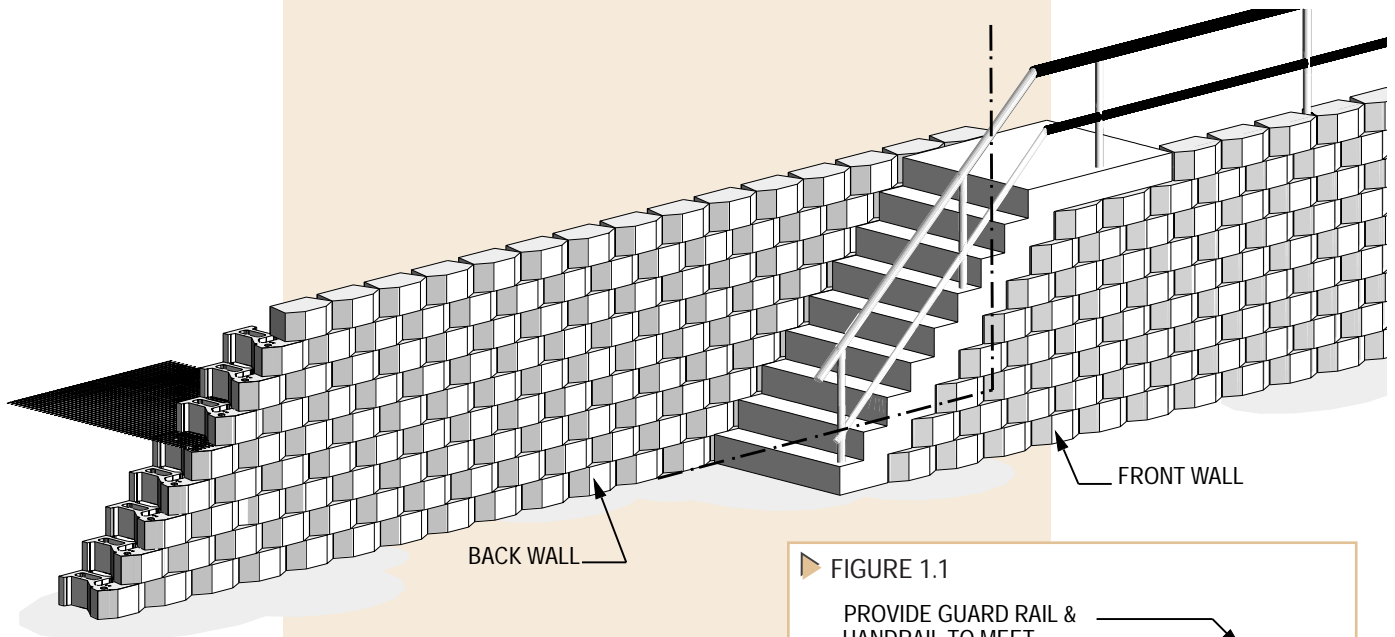

When building stairs on a project, a great design feature can include running the stairway parallel to the retaining wall as shown. This solution can minimize the area needed for a typical stair which runs perpendicular to the wall. The construction is typical to normal installation. Build the Keystone walls with proper soil reinforcement as per design. Offset the front wall by the desired stair width. The back wall only needs to be buried so that the cast in place stair hides the base condition of all units (see figure 1.2). Determine staircase rise and run requirements based on applicable building codes. Figure 1.1 shows cast in place stair poured over the Keystone units in a uniform dimension. If rise and run for stair require modifying the layout, Keystone units can be cut to allow for a change in horizontal dimensions.

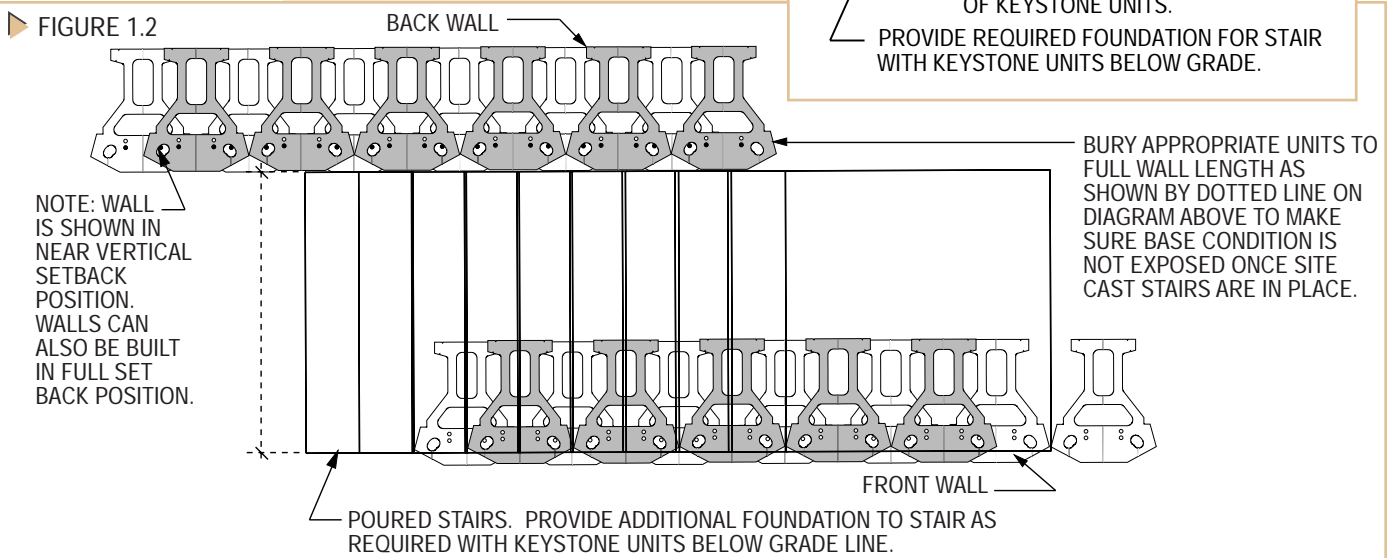
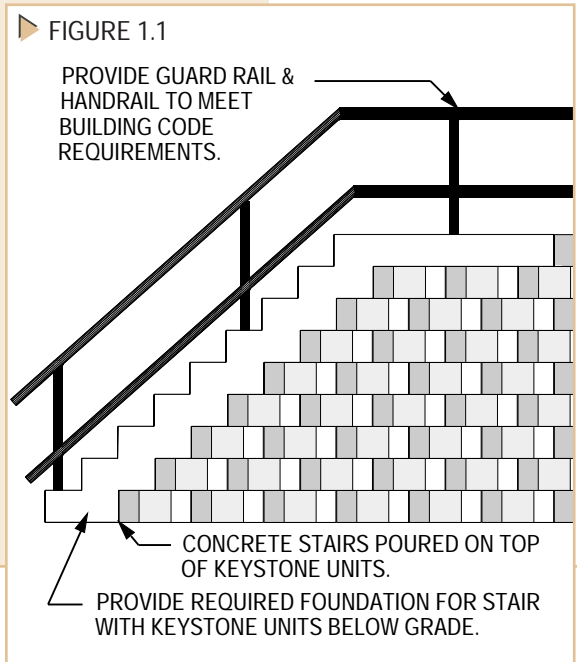

The information contained herein has been compiled by Keystone® Retaining Wall Systems, Inc. and to the best of our knowledge, accurately represents the Keystone product use in the applications which are illustrated. Final determination of the suitability for the use contemplated and its manner of use are the sole responsibility of the user. Structural design and analysis shall be performed by a qualified engineer.  
© 1997 KEYSTONE RETAINING WALL SYSTEMS, INC.  
Minneapolis, Minnesota • (612) 897-1040 • (612) 897-3858-fax