

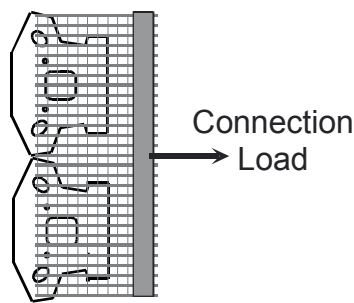

# Connection Strength

The connection capacity between geosynthetic soil reinforcement and a modular concrete wall unit is a complex interaction that can only be determined by laboratory testing. NCMA proposed a test method, SRWU-1, which outlines the accepted practice for connection testing and evaluation of the results which is utilized by Keystone. A schematic of the connection testing setup and laboratory developed load curves are shown below.



**Top View**

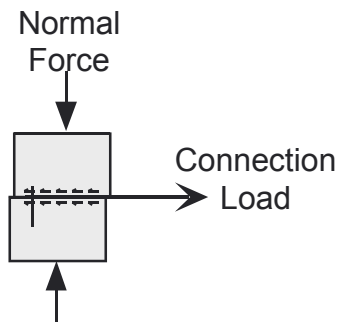

**Side View**

**Connection Test Setup**

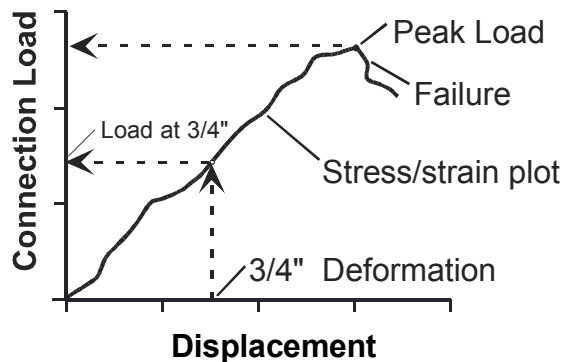

**Load test at one normal force**

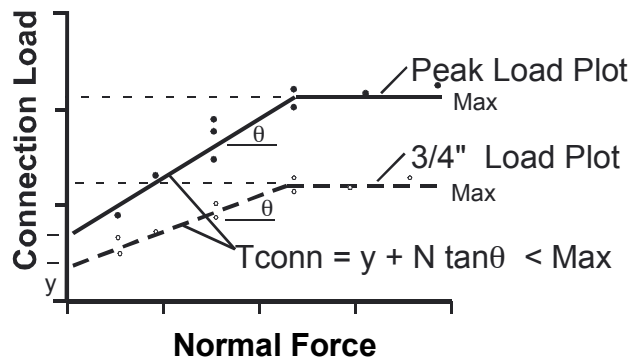

**Connection Load Plots**

Full laboratory connection testing has been performed with Keystone Standard and Compac units and geosynthetic soil reinforcement products by Tensar, Mirafi, Stratagrid, Huesker, and Amoco. This data is utilized in each wall design to determine the maximum permissible connection value that can be utilized at each reinforcement level.

The larger Standard unit has considerably more connection capacity than the smaller Compac unit and should be utilized where maximum design safety and high performance is required. Connection capacity is a limiting factor in many taller wall designs and should be carefully evaluated to conform with published design standards.