

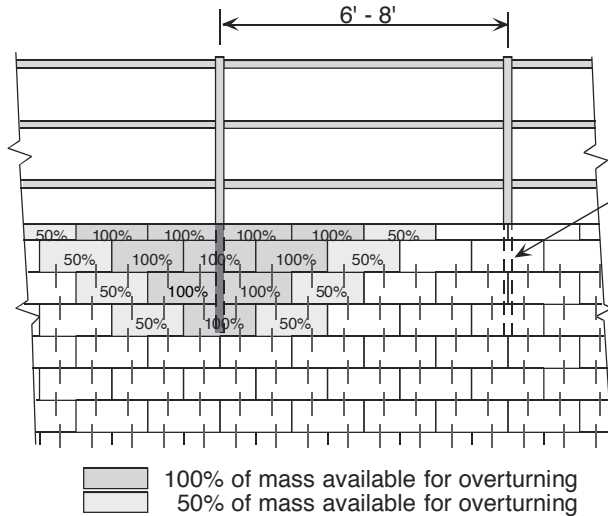

# Typical Railing Design

Direct Mount - 20 plf - Standard Units



Typical Railing Elevation

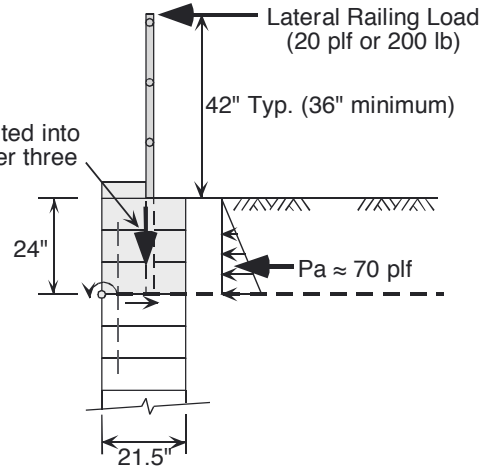

Typical Railing Design Section

## Introduction

It is difficult for a railing design to satisfy structural design requirements when considering the direct mounting on or into the Keystone modular wall system. The small unit size and mass provides minimal resistance to overturning by itself so a number of units must be engaged to provide the required resistance. The Keystone Standard Unit is typically large enough to satisfy a 20 plf or 200 lb/post minimum UBC loading provided that the post is grouted into the upper three courses as shown.

## Railing Analysis

Shear resistance of Standard units (>1000 plf) exceeds the driving forces by a wide margin in gravity wall applications and is not a critical evaluation. Overturning at the top of wall (local stability) is the critical evaluation. A 200 lb point load on each post typically controls with a 20 plf design criteria. The higher 50 plf loading required by UBC for more critical conditions and by AASHTO for highway projects requires that the top of wall analysis be treated differently.

### Driving Moments (20plf or 200 lb point load)

Railing	200 lbs x 5.5' arm	= 1100 ft-lbs
Soil	70 lb/ft x 0.67' x 2'	= 94 ft-lbs
Total		= 1194 ft-lbs

### Resisting Moments (grouted posts, units with gravel)

6 units x 215 lbs/ea x 100% x 0.89'	= 1148 ft-lbs
6 units x 215 lbs/ea x 50% x 0.89'	= 574 ft-lbs
4 caps x 50 lbs/ea x 100% x 0.45'	= 90 ft-lbs
2 caps x 50 lbs/ea x 50% x 0.45'	= 23 ft-lbs
Total	= 1835 ft-lbs

SFot = 1835/1194 = **1.53** ≥ 1.50 minimum, **OK**

### Design Note:

Keystone Standard units are always recommended in situations where railings are considered for direct mounting on the wall system.

Alternate railing designs that include extra geogrid levels purposely installed between the upper three courses to assist in resisting the overturning forces may be considered. These design alternatives require fully grouted cells with lateral reinforcement to provide a coherent mass for a 50 plf or greater loading. The reinforcement and top of wall detailing is more critical in these situations and the design more questionable.